



US007551142B1

(12) **United States Patent**
Zhang et al.

(10) **Patent No.:** **US 7,551,142 B1**
(45) **Date of Patent:** **Jun. 23, 2009**

(54) **HYBRID ANTENNAS WITH DIRECTLY FED ANTENNA SLOTS FOR HANDHELD ELECTRONIC DEVICES**

2003/0107518 A1 6/2003 Li et al.
2004/0145521 A1 7/2004 Hebron et al.
2004/0257283 A1* 12/2004 Asano et al. 343/702
2006/0055606 A1 3/2006 Boyle
2008/0231521 A1* 9/2008 Anguera Pros et al. 343/702

(75) Inventors: **Zhijun Zhang**, Beijing (CN); **Robert J. Hill**, Salinas, CA (US); **Robert W. Schlub**, Campbell, CA (US); **Juan Zavala**, Watsonville, CA (US); **Ruben Caballero**, San Jose, CA (US)

OTHER PUBLICATIONS

Hill et al. U.S. Appl. No. 11/650,187, filed Jan. 4, 2007.
Hill et al. U.S. Appl. No. 11/821,192, filed Jun. 21, 2007.
Hill et al. U.S. Appl. No. 11/897,033, filed Aug. 28, 2007.
Zhang et al. U.S. Appl. No. 11/895,053, filed Aug. 22, 2007.

(73) Assignee: **Apple Inc.**, Cupertino, CA (US)

* cited by examiner

(*) Notice: Subject to any disclaimer, the term of this patent is extended or adjusted under 35 U.S.C. 154(b) by 0 days.

Primary Examiner—Anh Q Tran
(74) *Attorney, Agent, or Firm*—Treyz Law Group; G. Victor Treyz; David C. Kellogg

(21) Appl. No.: **11/956,314**

(57) **ABSTRACT**

(22) Filed: **Dec. 13, 2007**

A handheld electronic device is provided that contains wireless communications circuitry. The wireless communications circuitry may include antennas. An antenna in the handheld electronic device may have a ground plane element. A slot antenna resonating element may be formed from an opening in the ground plane element. A near-field-coupled antenna resonating element may be electromagnetically coupled to the slot antenna resonating element through electromagnetic near-field coupling. A transmission line may directly feed the slot antenna resonating element. The transmission line may indirectly feed the near-field-coupled antenna resonating element through the slot antenna resonating element. The slot antenna resonating element may have one or more associated resonant frequencies and the near-field-coupled antenna resonating element may have one or more associated resonant frequencies. The antenna may be configured to cover one or more distinct communications bands.

(51) **Int. Cl.**
H01Q 1/24 (2006.01)

(52) **U.S. Cl.** **343/702; 343/700 MS**

(58) **Field of Classification Search** **343/700 MS, 343/702**

See application file for complete search history.

(56) **References Cited**

U.S. PATENT DOCUMENTS

6,670,923 B1 12/2003 Kadambi et al.
6,741,214 B1 5/2004 Kadambi et al.
6,747,601 B2 6/2004 Boyle
6,856,294 B2 2/2005 Kadambi et al.
6,980,154 B2 12/2005 Vance et al.
7,027,838 B2 4/2006 Zhou et al.
7,116,267 B2 10/2006 Schuster et al.
7,119,747 B2 10/2006 Lin et al.
7,123,208 B2 10/2006 Puente Baliarda et al.

14 Claims, 24 Drawing Sheets

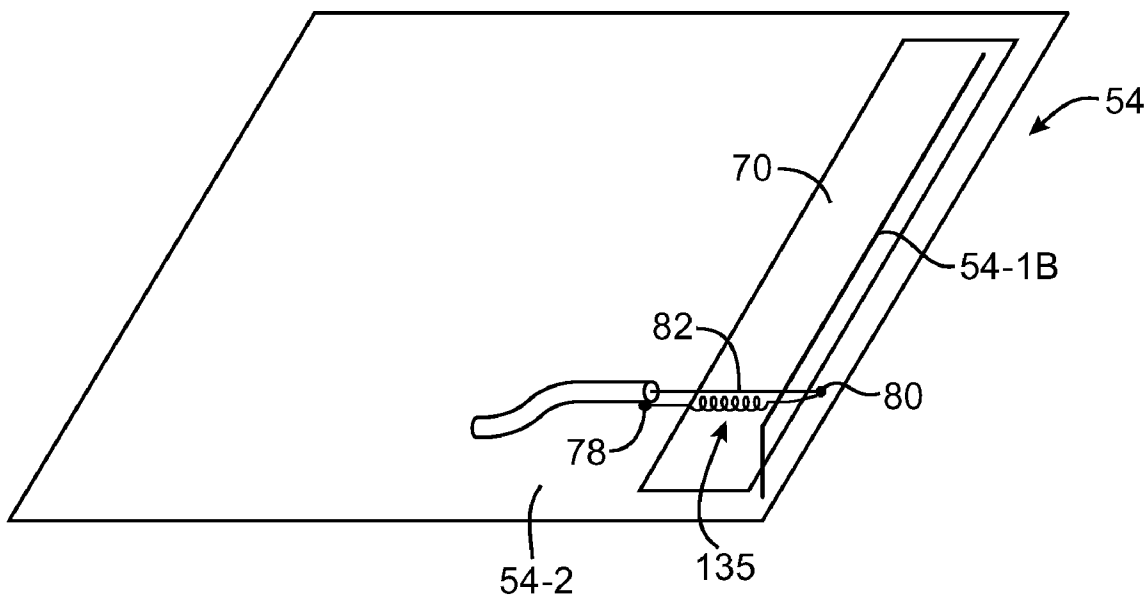

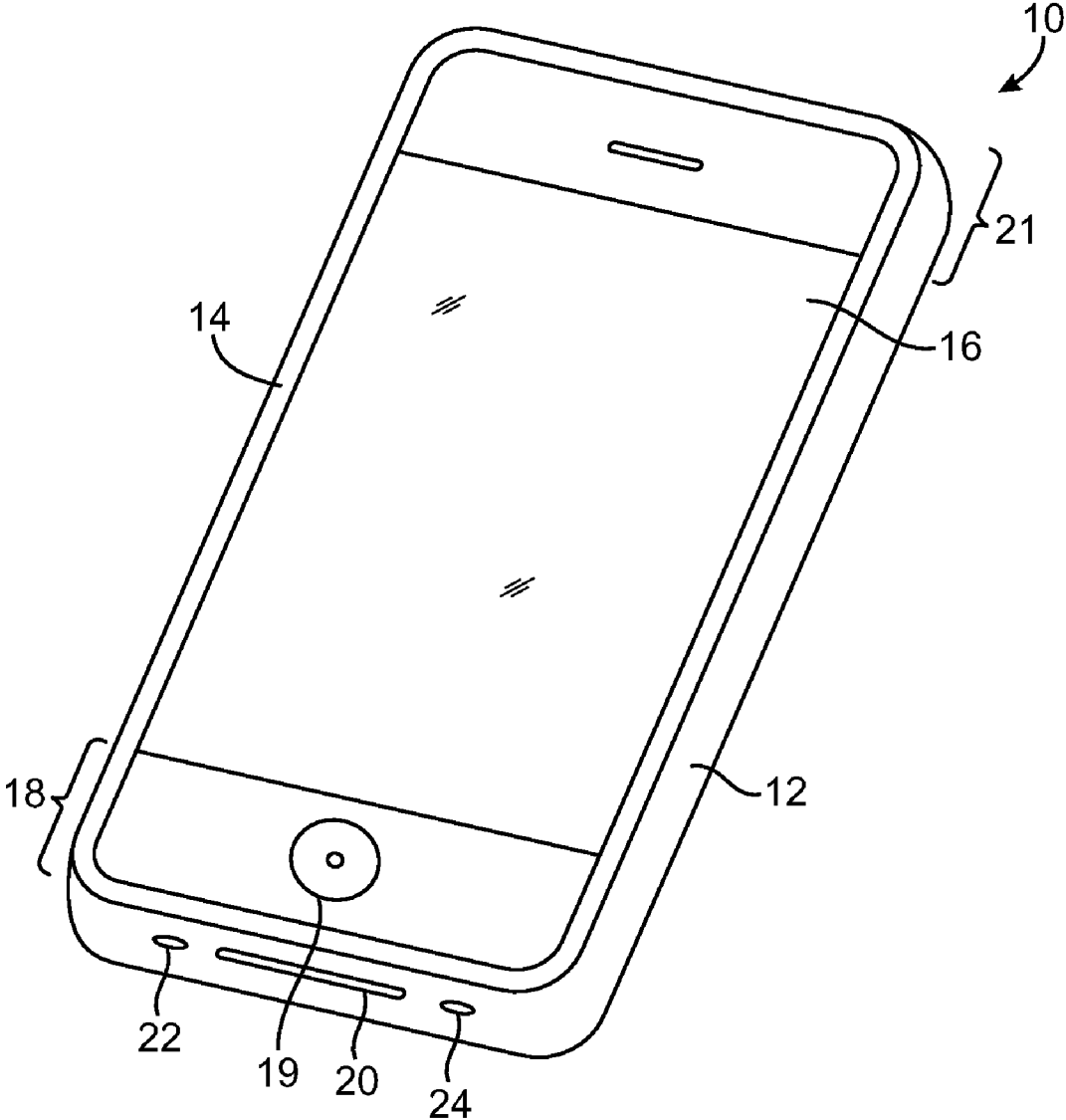

FIG. 1

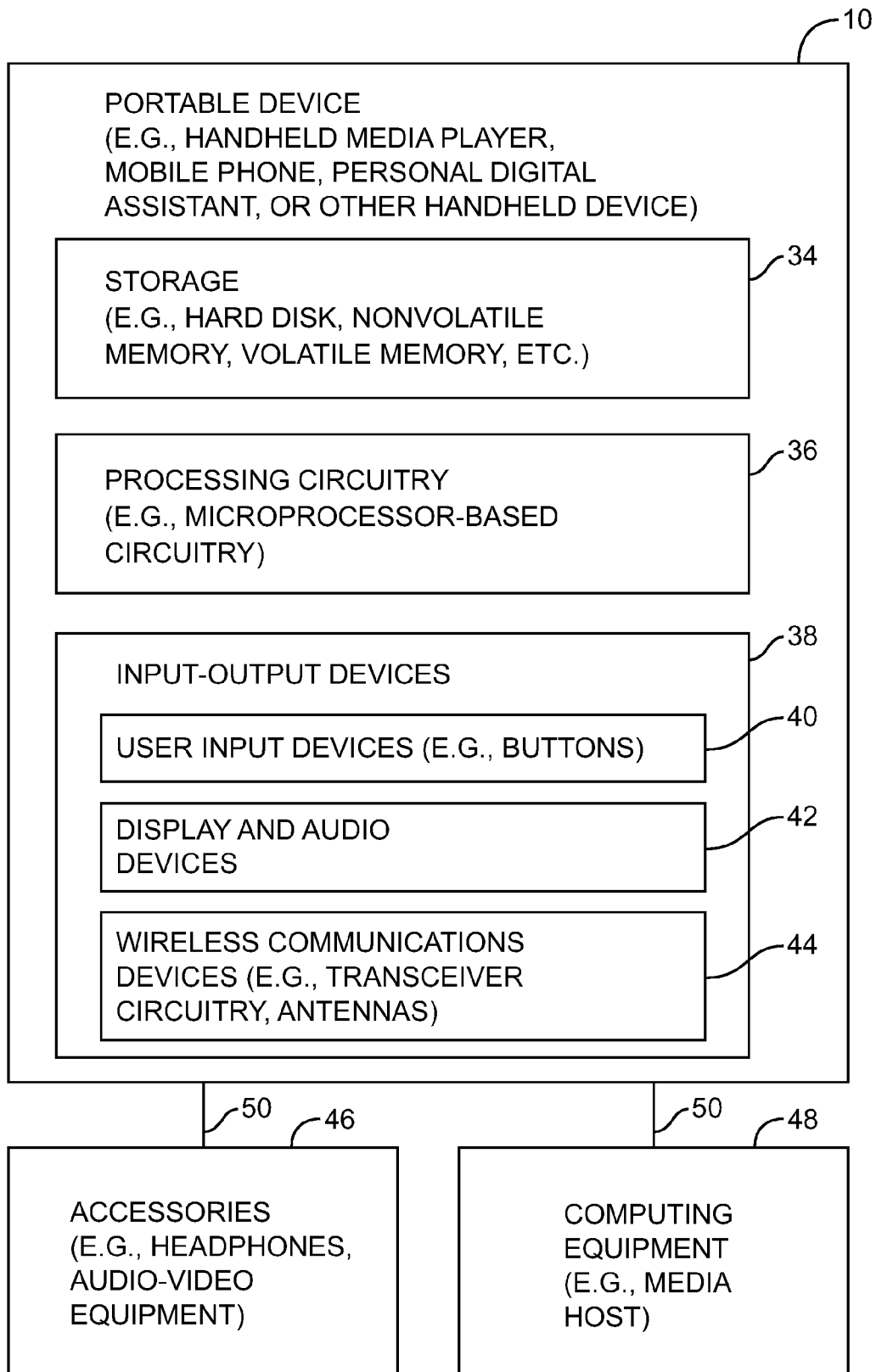

FIG. 2

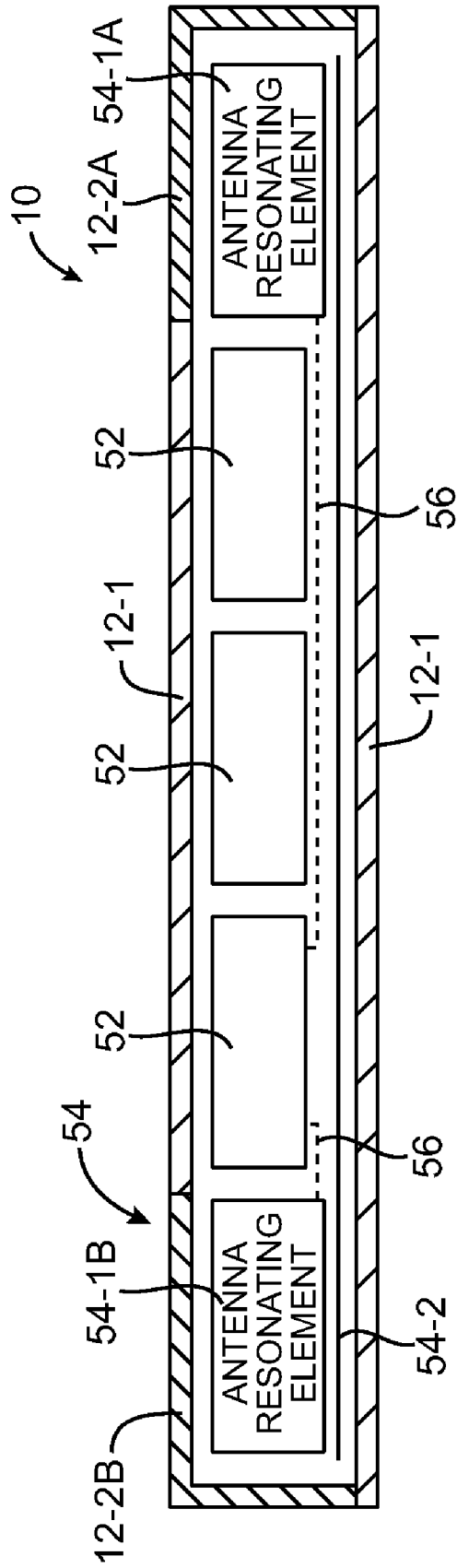

FIG. 3

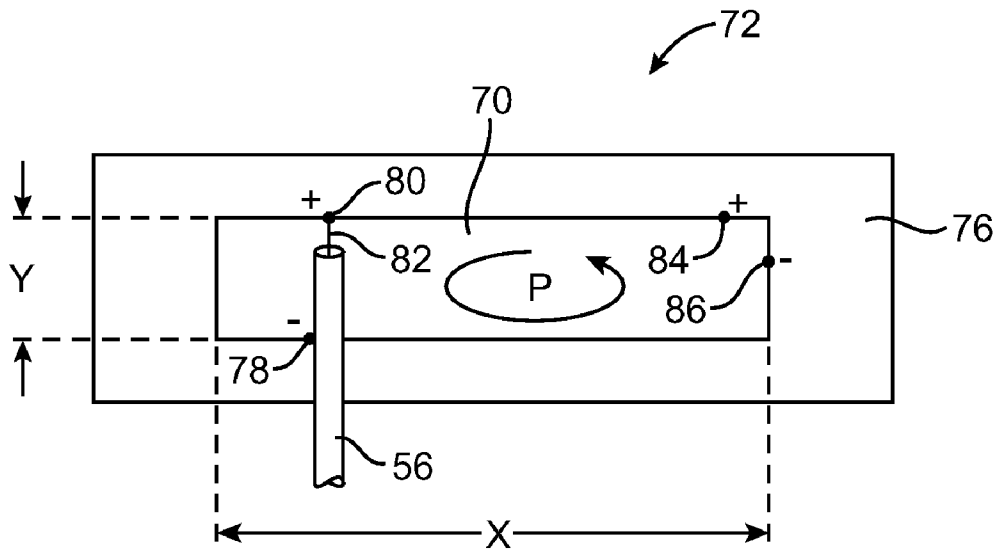

FIG. 4

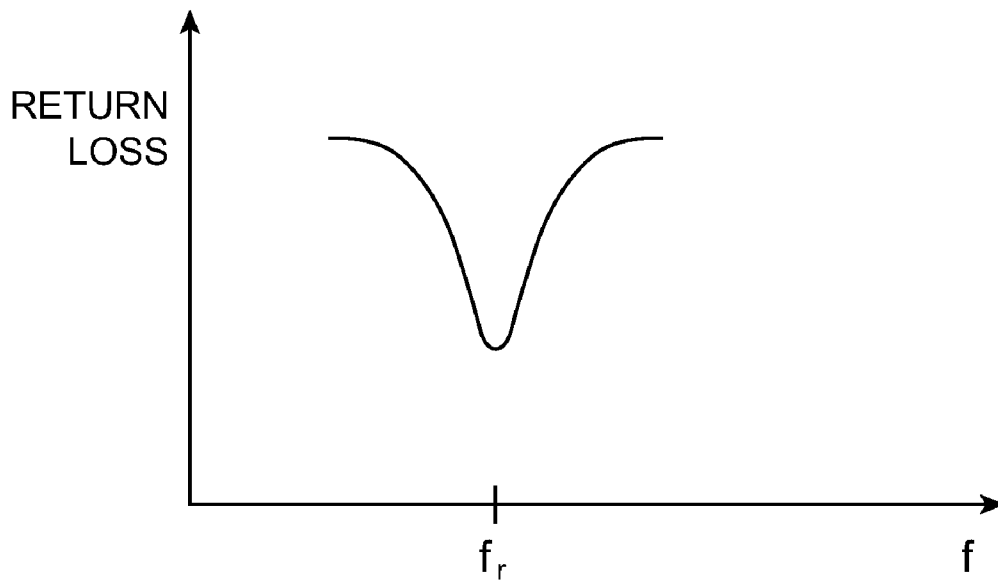

FIG. 5

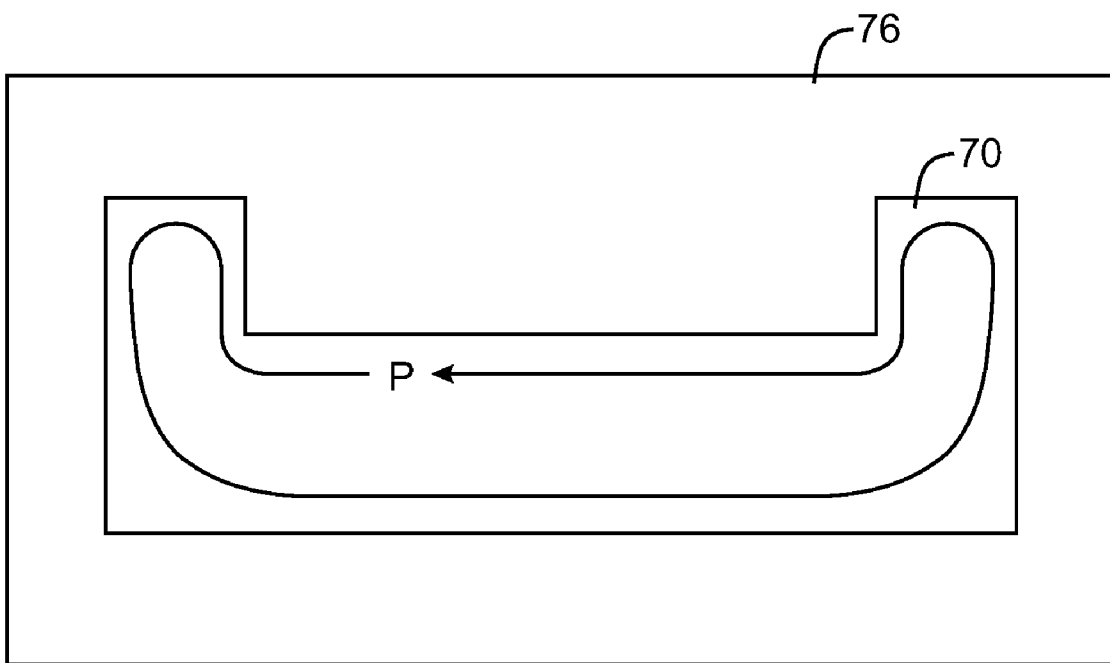

FIG. 6

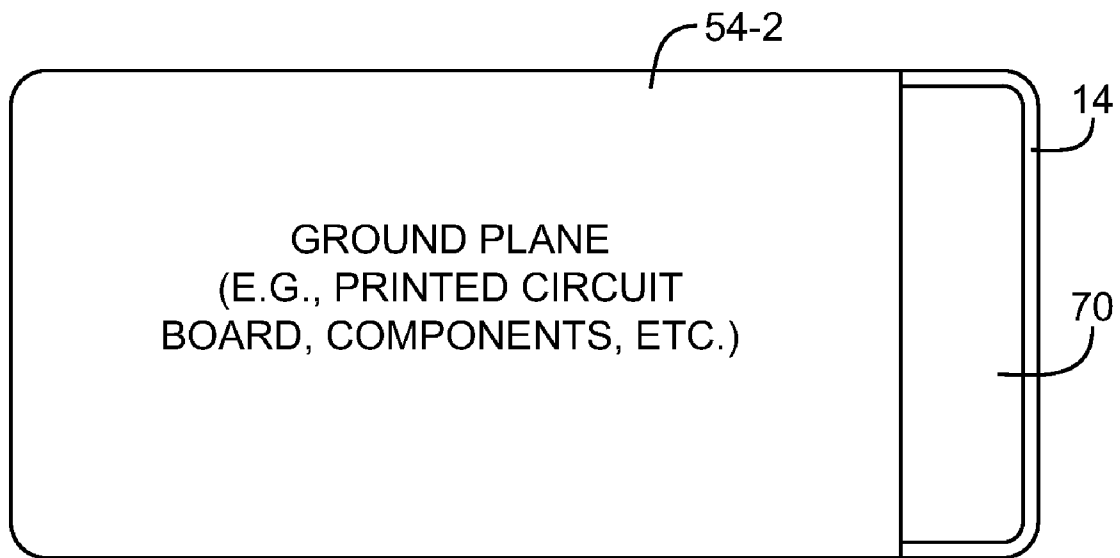

FIG. 7

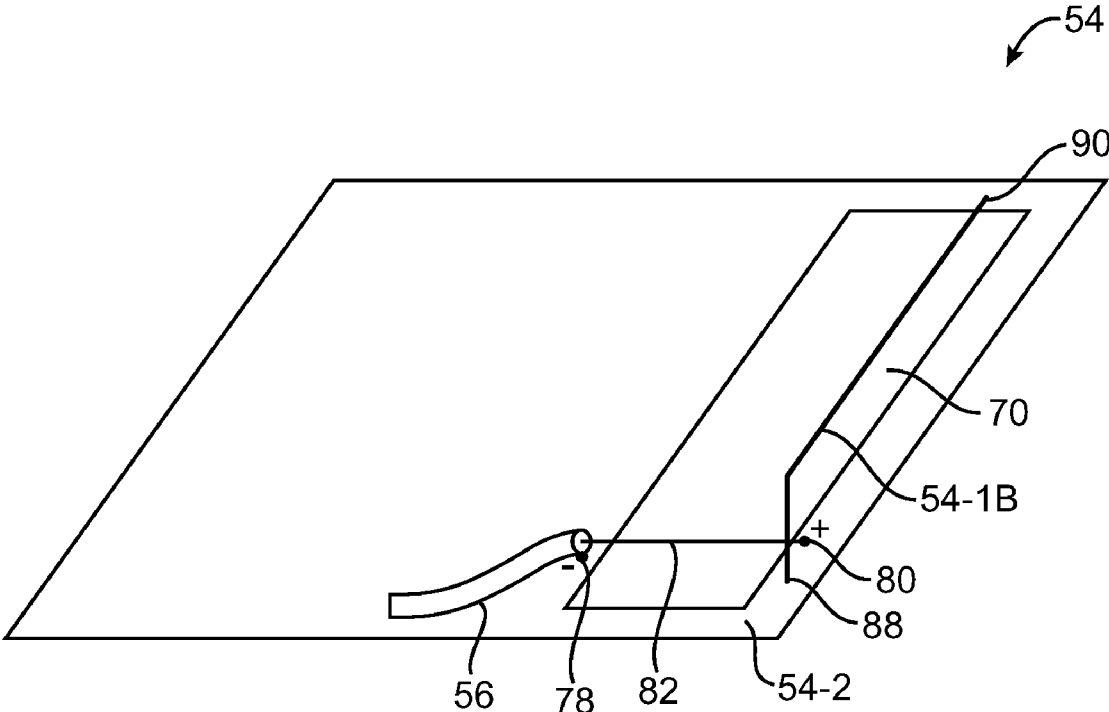

FIG. 8

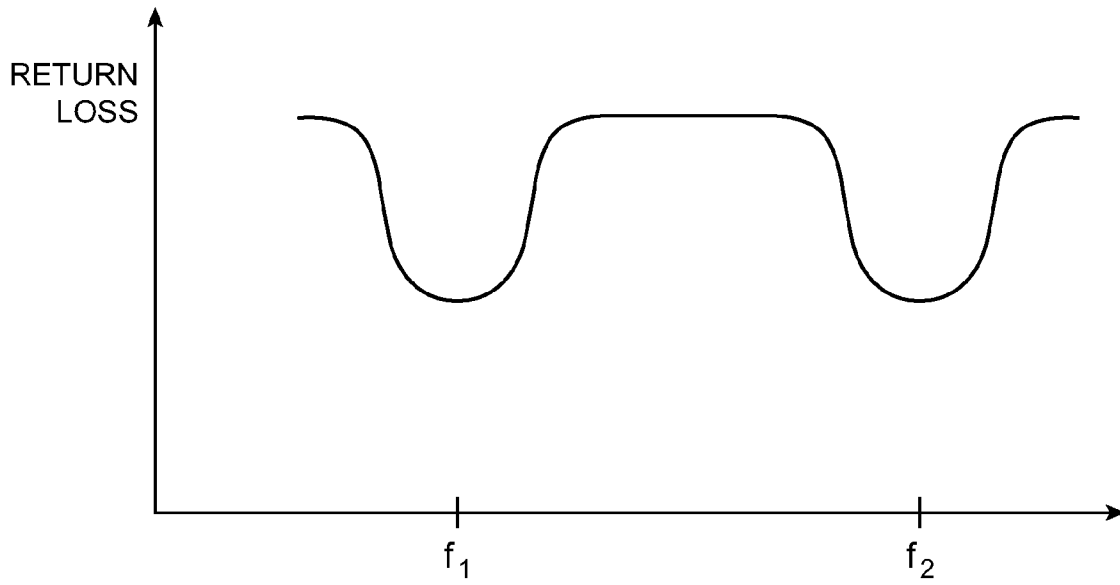

FIG. 9

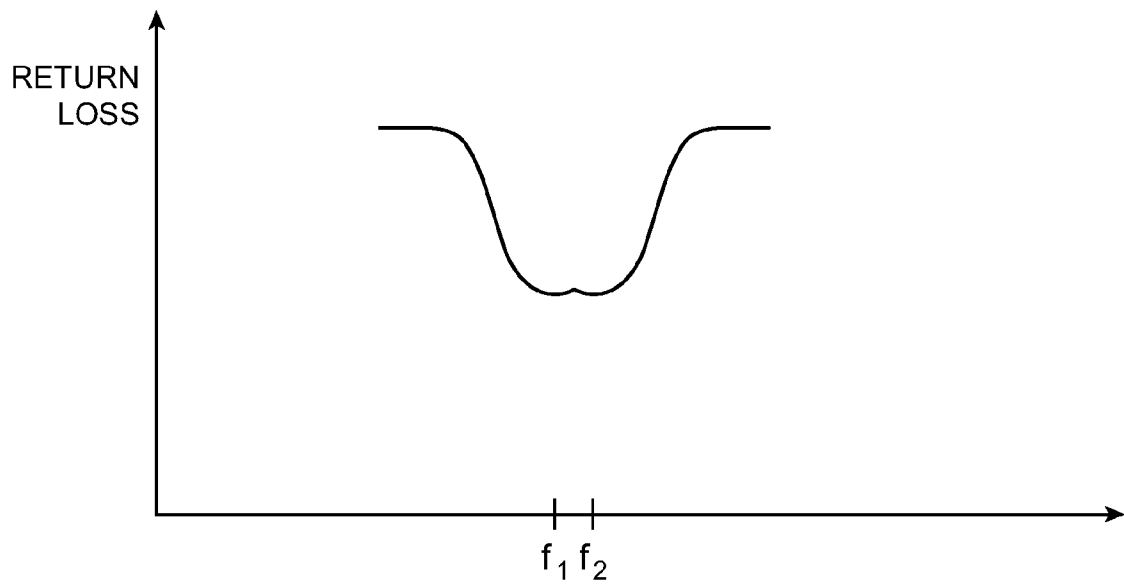

FIG. 10

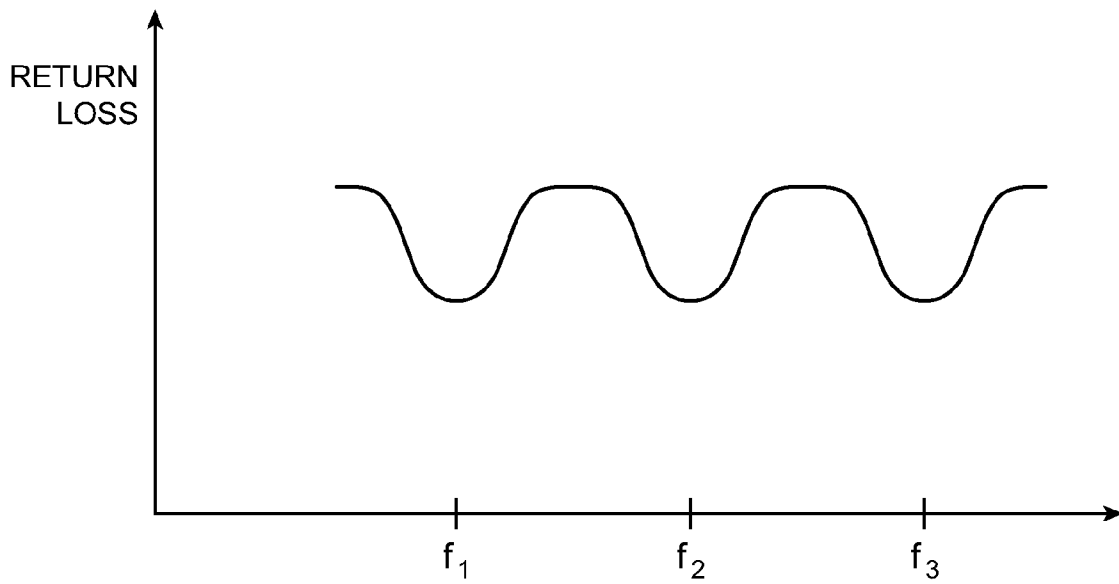

FIG. 11

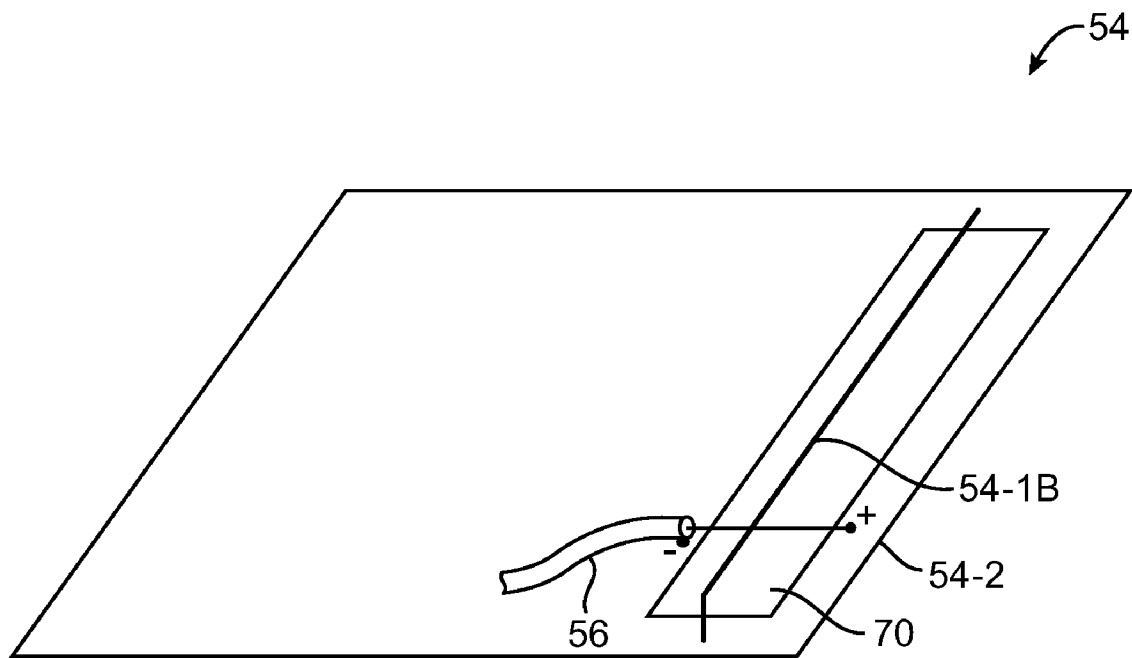

FIG. 12

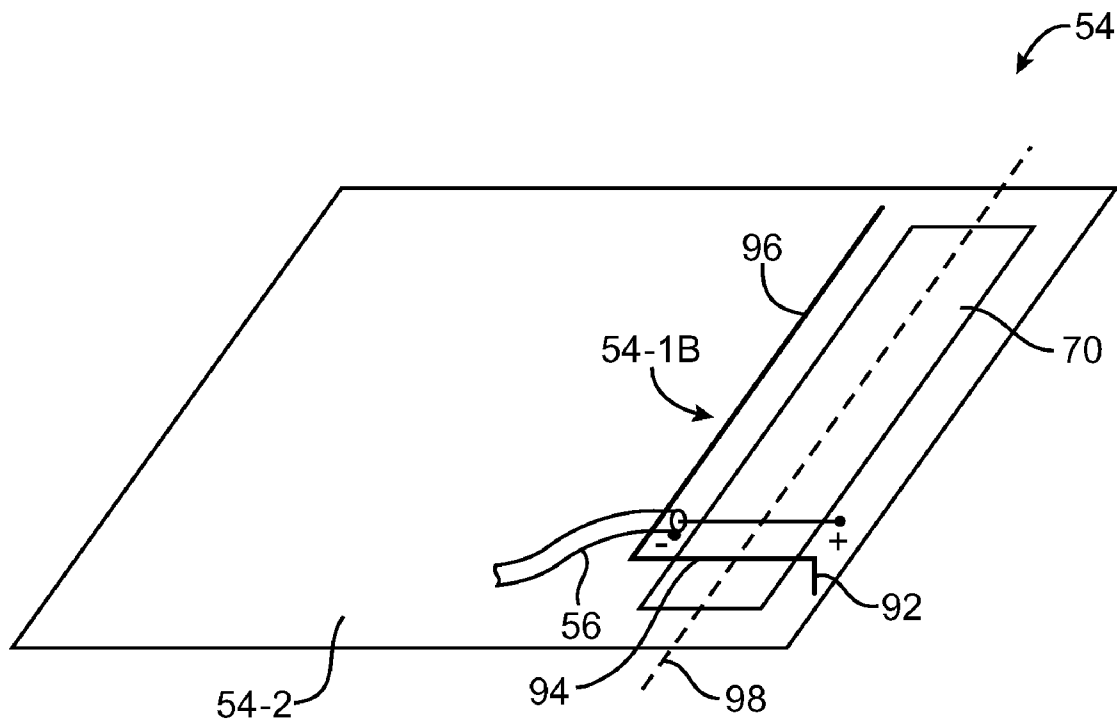

FIG. 13

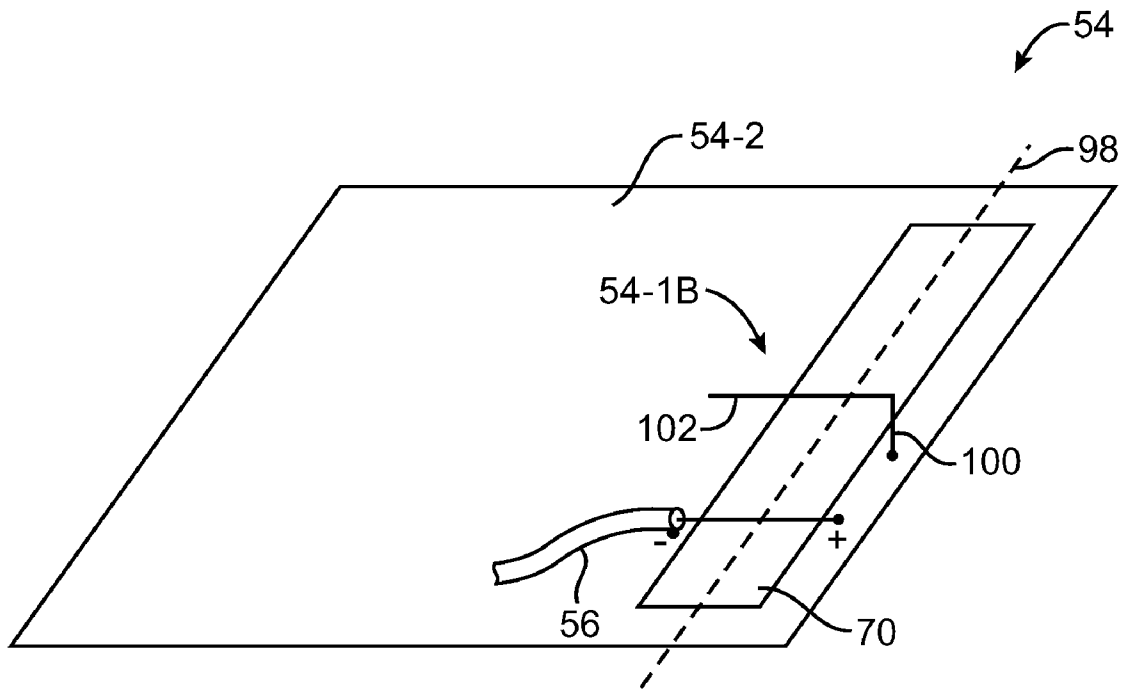

FIG. 14

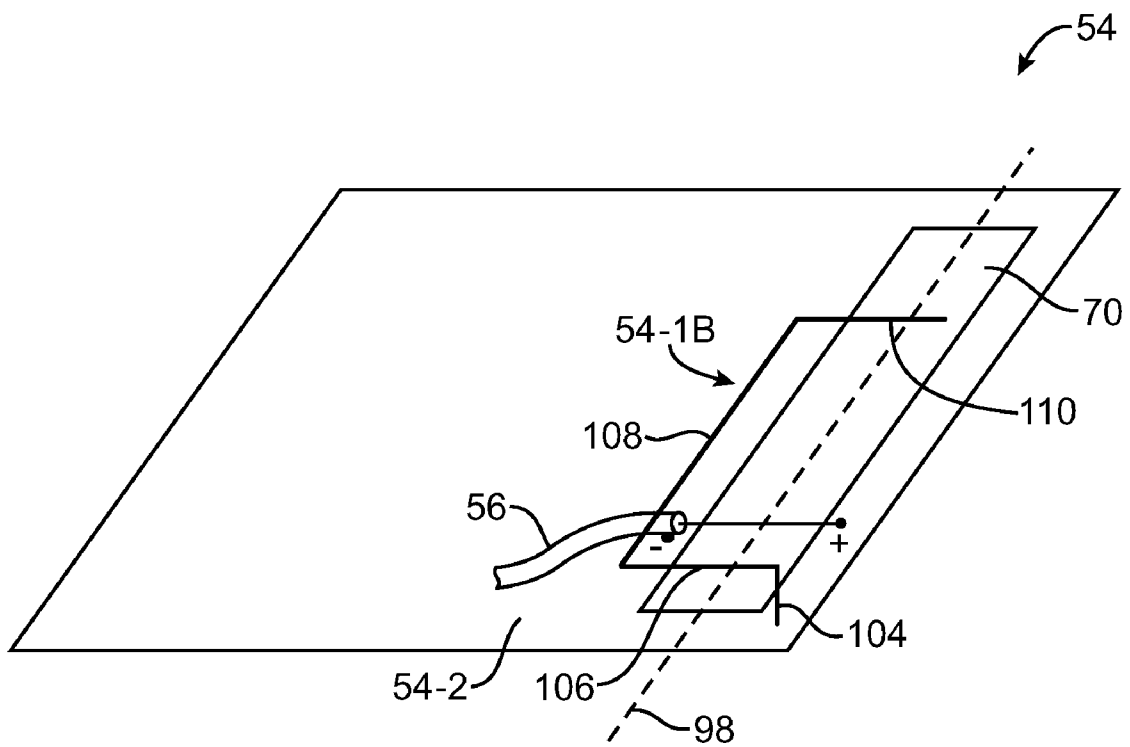

FIG. 15

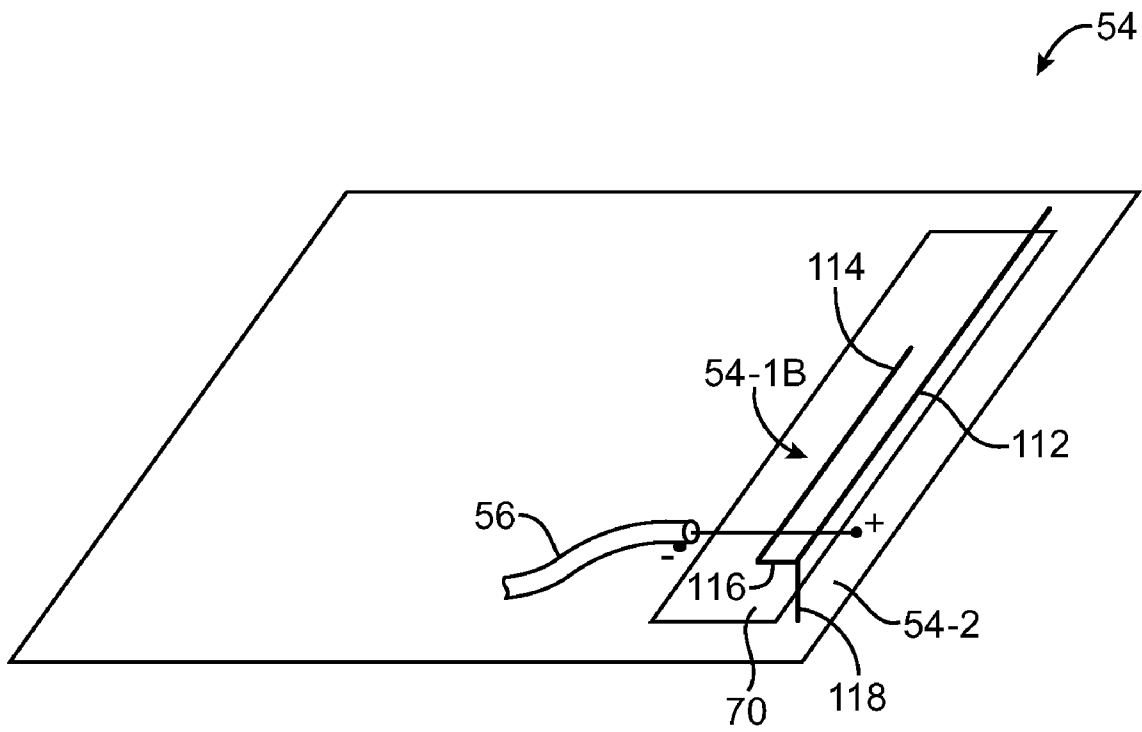

FIG. 16

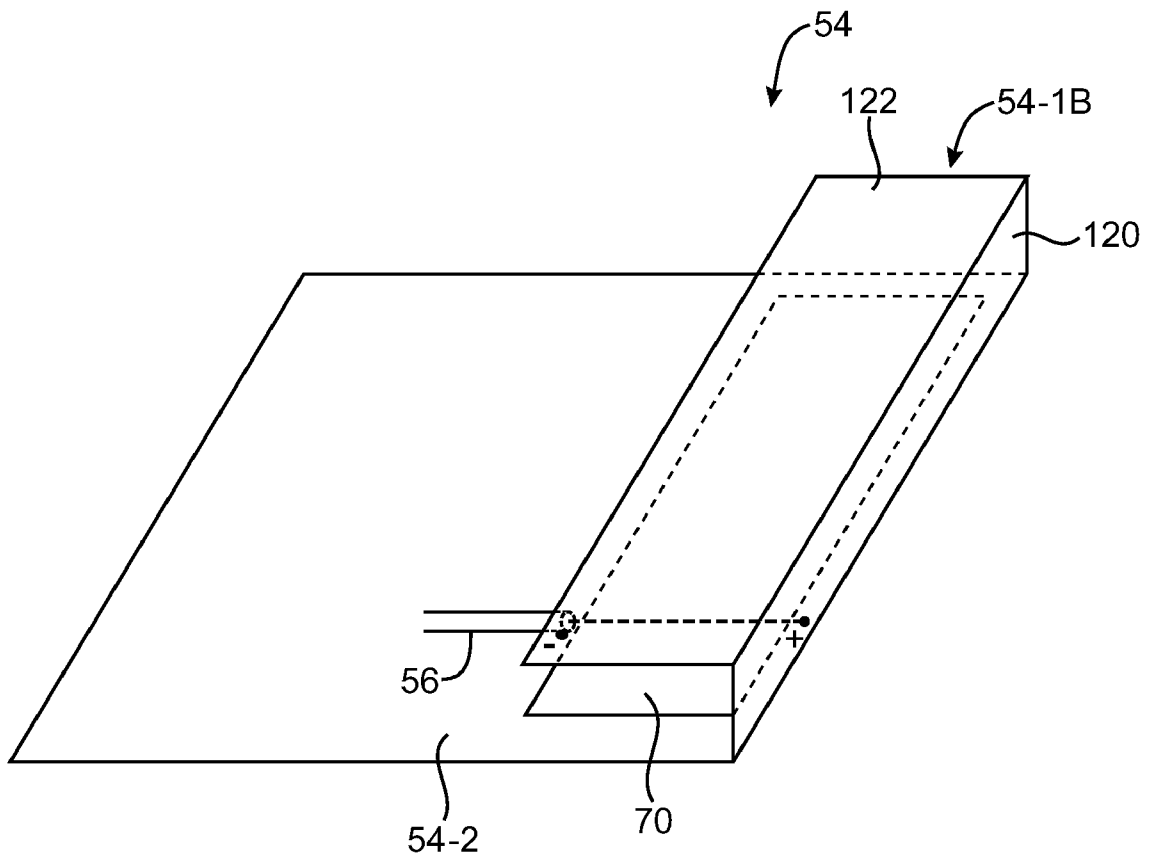

FIG. 17

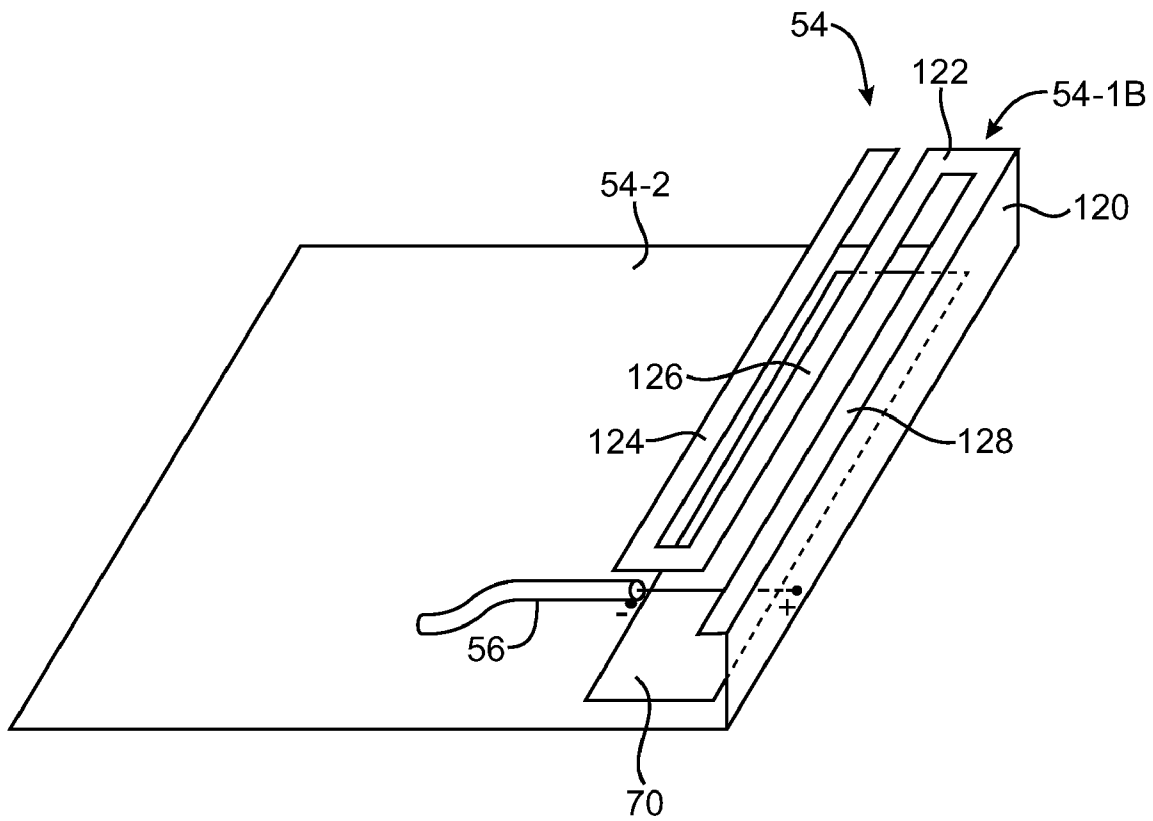

FIG. 18

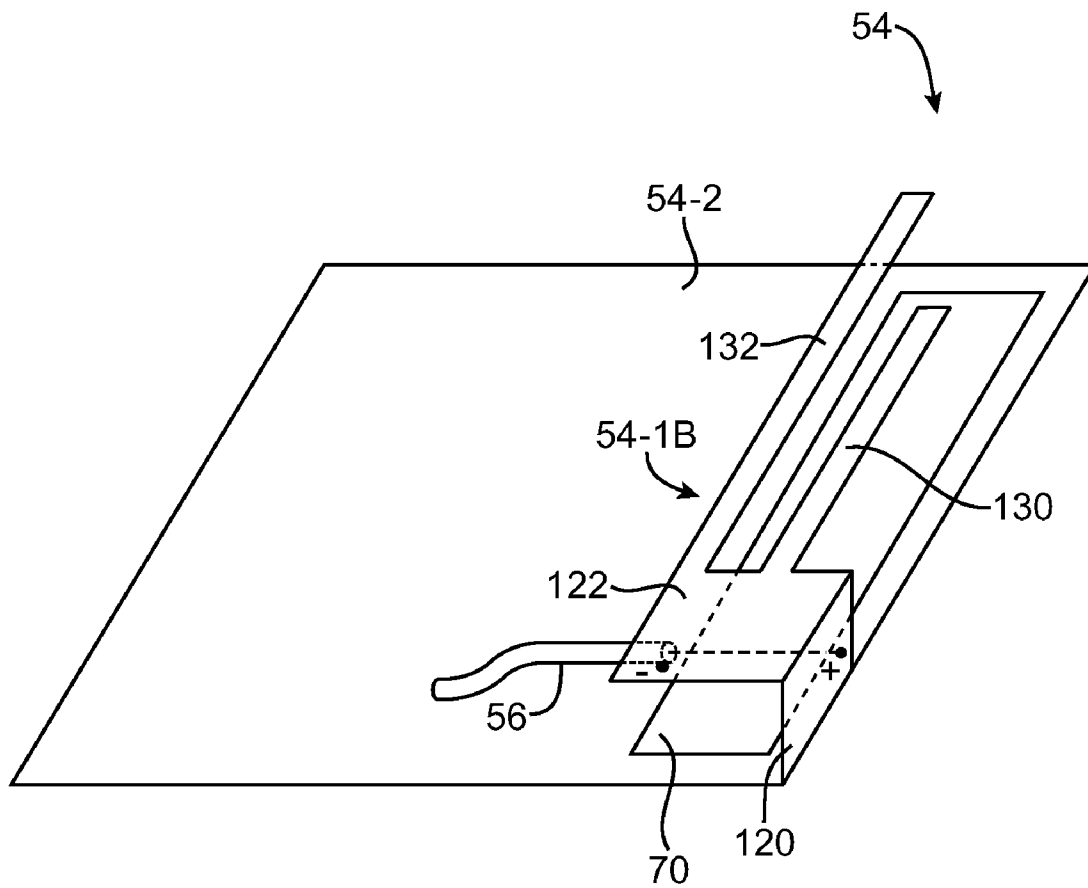

FIG. 19

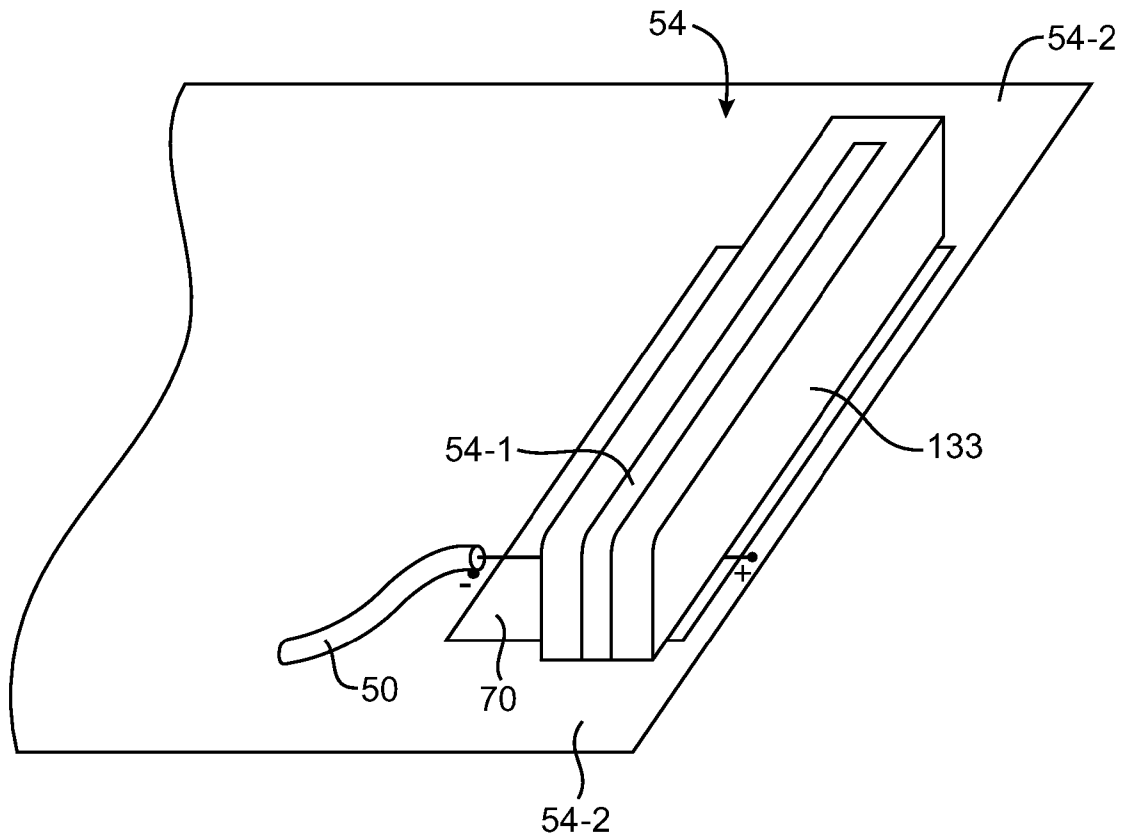

FIG. 20

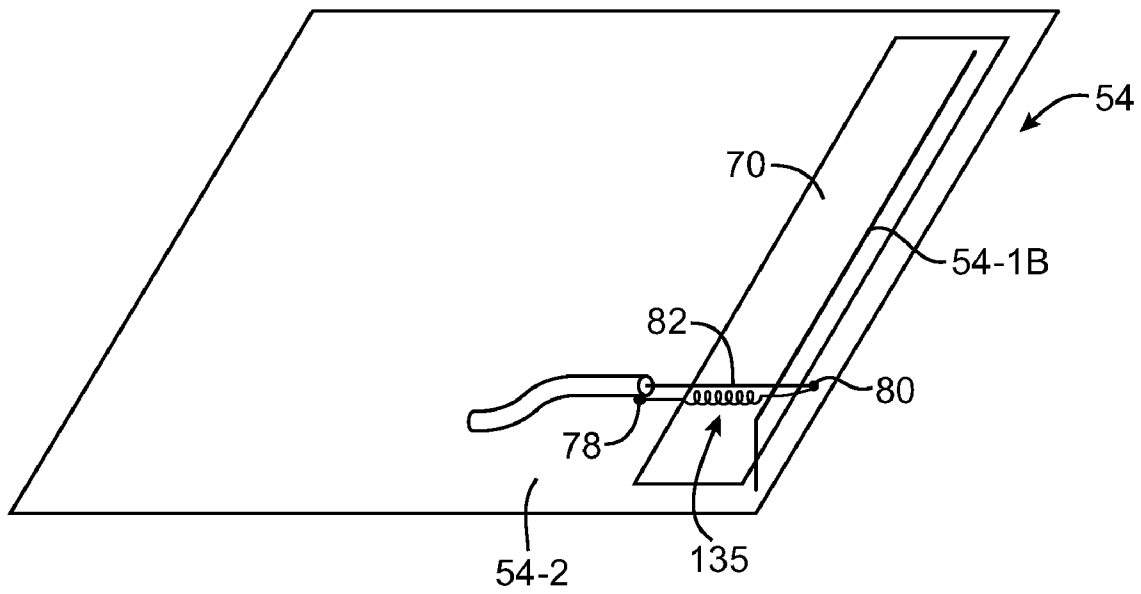

FIG. 21

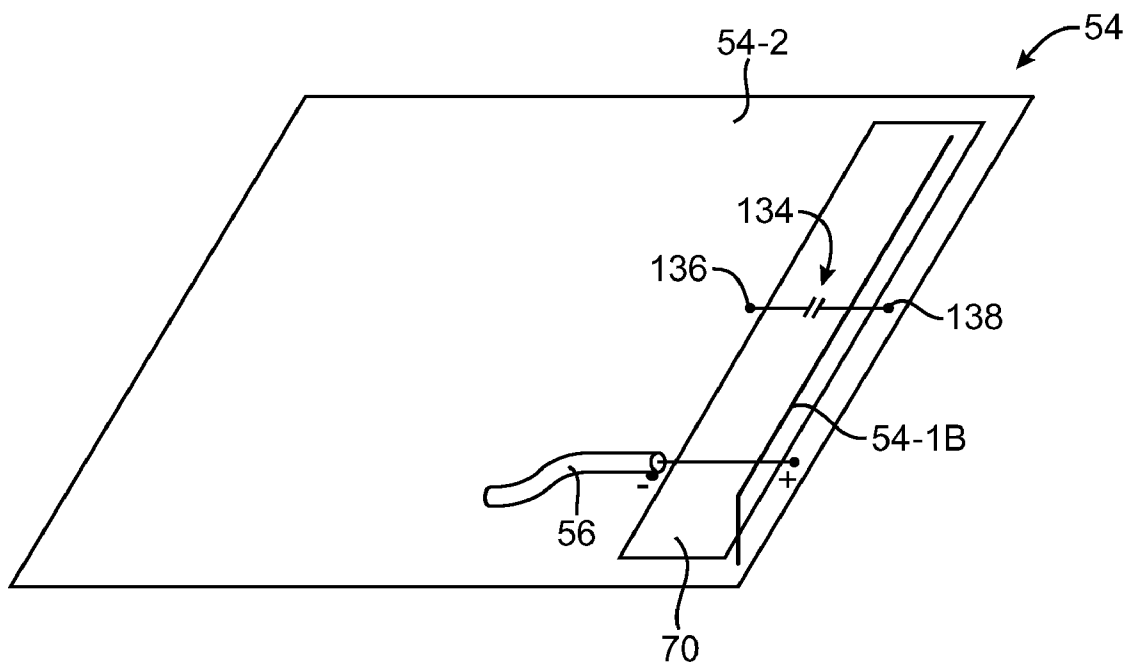

FIG. 22

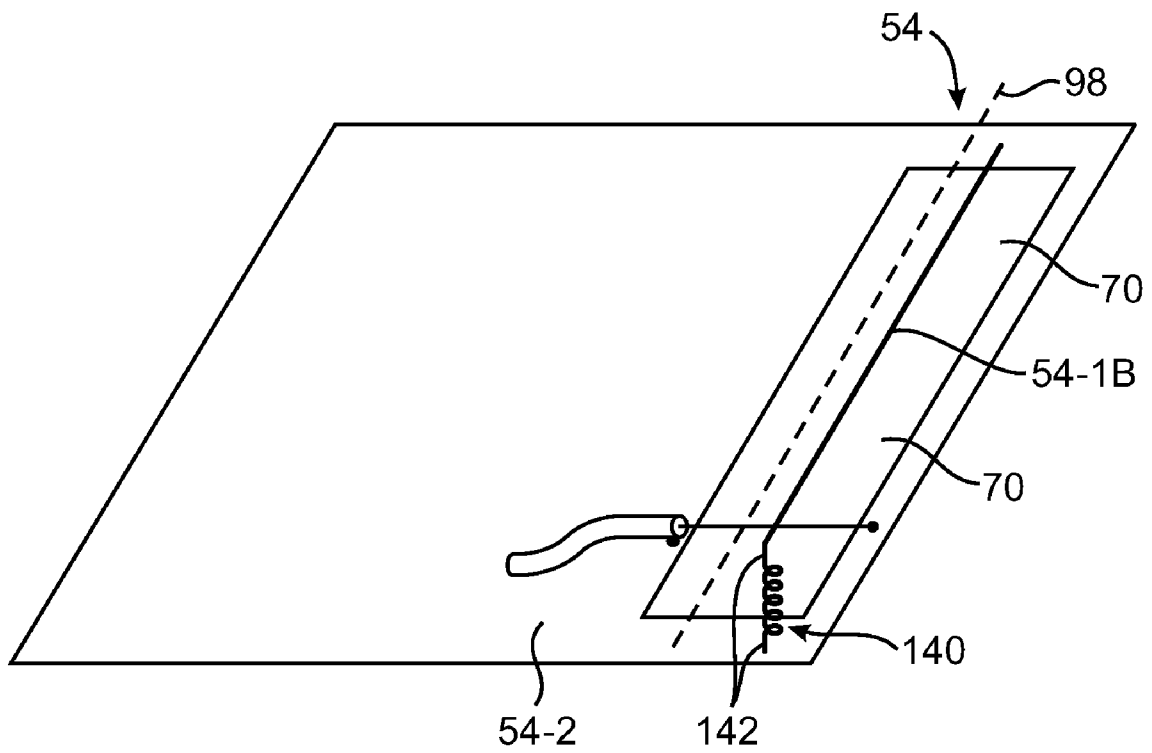

FIG. 23

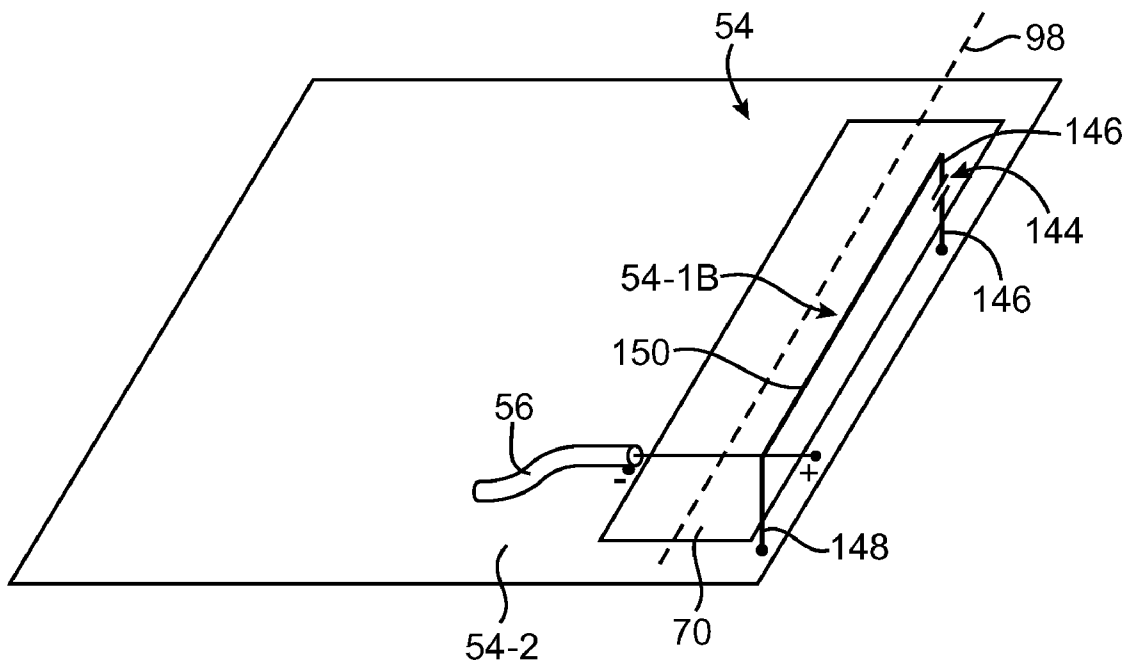

FIG. 24

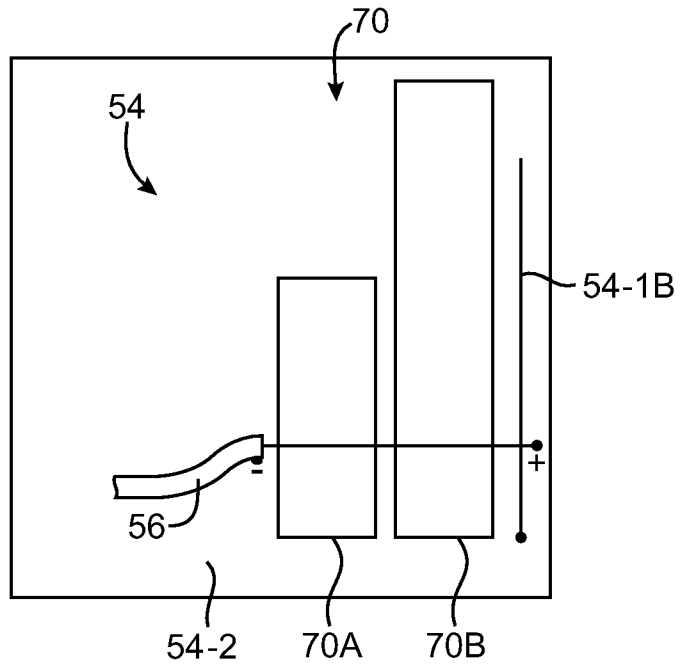

FIG. 25

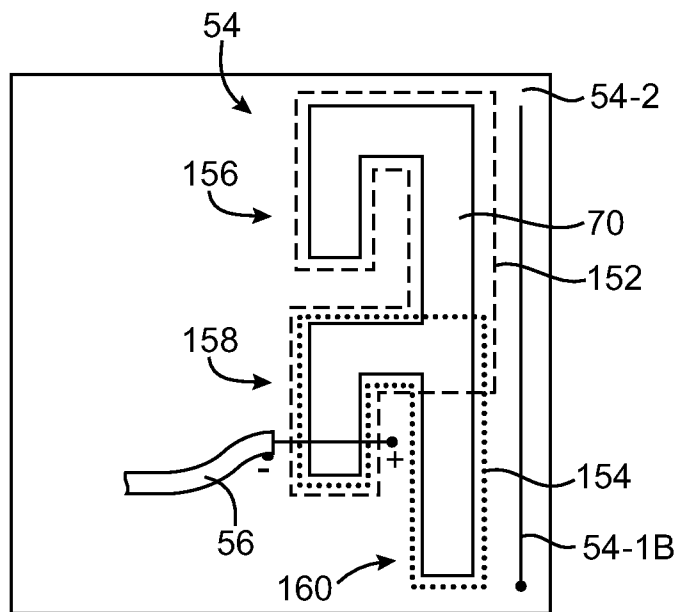

FIG. 26

HYBRID ANTENNAS WITH DIRECTLY FED ANTENNA SLOTS FOR HANDHELD ELECTRONIC DEVICES

BACKGROUND

This invention relates generally to wireless communications circuitry, and more particularly, to wireless communications circuitry for handheld electronic devices.

Handheld electronic devices are becoming increasingly popular. Examples of handheld devices include handheld computers, cellular telephones, media players, and hybrid devices that include the functionality of multiple devices of this type.

Due in part to their mobile nature, handheld electronic devices are often provided with wireless communications capabilities. Handheld electronic devices may use long-range wireless communications to communicate with wireless base stations. For example, cellular telephones may communicate using cellular telephone bands at 850 MHz, 900 MHz, 1800 MHz, and 1900 MHz. Handheld electronic devices may also use short-range wireless communications links. For example, handheld electronic devices may communicate using the Wi-Fi® (IEEE 802.11) band at 2.4 GHz and the Bluetooth® band at 2.4 GHz. Communications are also possible in data service bands such as the 3G data communications band at 2170 MHz (commonly referred to as the UMTS or Universal Mobile Telecommunications System band). Handheld devices with Global Positioning System (GPS) capabilities receive GPS signals at 1575 MHz.

To satisfy consumer demand for small form factor wireless devices, manufacturers are continually striving to reduce the size of components that are used in these devices. For example, manufacturers have made attempts to miniaturize the antennas used in handheld electronic devices.

A typical antenna may be fabricated by patterning a metal layer on a circuit board substrate or may be formed from a sheet of thin metal using a foil stamping process. Antennas such as planar inverted-F antennas (PIFAs) and antennas based on L-shaped resonating elements can be fabricated in this way. Antennas such as PIFA antennas and antennas with L-shaped resonating elements can be used in handheld devices.

Although modern handheld electronic devices often need to function over fairly wide frequency bands or over a number of different communications bands, it is difficult to design a compact antenna that covers all frequencies of interest while satisfying design constraints related to antenna efficiency and immunity to proximity effects.

It would therefore be desirable to be able to provide improved antennas and wireless handheld electronic devices.

SUMMARY

Handheld electronic devices and antennas for handheld electronic devices are provided. A handheld electronic device may have conductive structures that form an antenna ground plane element. The ground plane element may have portions that define a slot antenna resonating element. Another antenna resonating element may be electromagnetically coupled to the slot antenna resonating element through electromagnetic near-field coupling. During operation, a coaxial cable or other transmission line in a handheld electronic device may directly feed the slot antenna resonating element and may indirectly feed the near-field-coupled antenna resonating element through the slot antenna resonating element.

The slot antenna resonating element may have multiple openings or branches that define multiple associated inner slot perimeters and thereby allow the slot antenna resonating element to resonate at multiple resonant frequencies. The near-field-coupled antenna resonating element may have multiple branches that allow the near-field-coupled antenna resonating element to resonate at multiple frequencies. The resonant peaks associated with the slot antenna resonating element portion of the antenna and the near-field-coupled antenna resonating element portion of the antenna can be configured to nearly or exactly coincide with each other to broaden the bandwidth of a given communications band or can be configured to provide coverage for distinct communications bands. In some configurations, the use of more than one antenna resonating element to transmit and receive radio-frequency signals for a handheld electronic device may make the antenna and handheld electronic device less susceptible to influences from a user's hand position.

A handheld electronic device may have a conductive housing and a conductive bezel. The conductive housing and conductive bezel may be used in defining the shape of the slot antenna resonating element. The slot antenna resonating element may be approximately rectangular in shape and may have a longitudinal axis. Non-rectangular shapes may also be used for the slot. The near-field-coupled antenna resonating element may have a portion that runs parallel to the longitudinal axis of the slot antenna resonating element and may have portions that run perpendicular to the longitudinal axis of the slot antenna resonating element while remaining parallel to a planar ground plane element.

The antenna may be provided with electrical components such as inductors and capacitors. For example, a capacitor may be placed across the slot antenna resonating element or may be used to terminate one end of the near-field-coupled resonating element to ground. An inductor may be incorporated at one end of the near-field-coupled resonating element or may be placed across the antenna feed terminals.

The near-field-coupled antenna resonating element may be formed from wires or other lengths of conductor or may contain planar portions that lie parallel to planar portions of the antenna's ground plane. For example, the near-field-coupled antenna resonating element may have planar conductive portions with multiple branches or serpentine paths that lie parallel to a planar ground plane element. The ground plane of the handheld electronic device may include planar elements such as a conductive housing or a printed circuit board ground conductor.

Further features of the invention, its nature and various advantages will be more apparent from the accompanying drawings and the following detailed description of the preferred embodiments.

BRIEF DESCRIPTION OF THE DRAWINGS

FIG. 1 is a perspective view of an illustrative handheld electronic device with antenna structures in accordance with an embodiment of the present invention.

FIG. 2 is a schematic diagram of an illustrative handheld electronic device with antenna structures in accordance with an embodiment of the present invention.

FIG. 3 is a cross-sectional side view of an illustrative handheld electronic device with antenna structures in accordance with an embodiment of the present invention.

FIG. 4 is a top view of an illustrative slot antenna in accordance with an embodiment of the present invention.

FIG. 5 is an illustrative antenna performance graph for an antenna of the type shown in FIG. 4 in which return loss

values are plotted as a function of operating frequency in accordance with an embodiment of the present invention.

FIG. 6 is a top view of an illustrative non-rectangular slot antenna structure in accordance with an embodiment of the present invention.

FIG. 7 is a top interior view of an illustrative handheld electronic device in which a slot antenna structure has a shape determined by the relative positions of a conductive bezel and a ground plane structure in accordance with an embodiment of the present invention.

FIG. 8 is a perspective view of an illustrative antenna having a directly fed slot antenna resonating element and an indirectly fed (near-field coupled) L-shaped strip resonating element in accordance with an embodiment of the present invention.

FIG. 9 is an antenna performance graph for an illustrative antenna having a directly fed slot antenna resonating element and an indirectly fed antenna resonating element in which return loss values are plotted as a function of operating frequency that shows how two separate communications bands may be covered in accordance with an embodiment of the present invention.

FIG. 10 is an antenna performance graph for an illustrative antenna having a directly fed slot antenna resonating element and an indirectly fed antenna resonating element in which return loss values are plotted as a function of operating frequency that shows how use of two resonating elements with overlapping resonant frequencies may broaden coverage for a single communications band in accordance with an embodiment of the present invention.

FIG. 11 is an antenna performance graph for an illustrative antenna having a directly fed slot antenna resonating element and an indirectly fed antenna resonating element in which return loss values are plotted as a function of operating frequency that shows how more than two communications bands may be covered in accordance with an embodiment of the present invention.

FIGS. 12, 13, 14, and 15 are perspective views of illustrative antennas having directly fed slot antenna resonating elements and indirectly fed (near-field-coupled) antenna resonating elements in accordance with embodiments of the present invention.

FIG. 16 is a perspective view of an illustrative antenna having a directly fed slot antenna resonating element and an indirectly fed multibranch antenna resonating element in accordance with an embodiment of the present invention.

FIG. 17 is a perspective view of an illustrative antenna having a directly fed slot antenna resonating element and an indirectly fed planar antenna resonating element in accordance with an embodiment of the present invention.

FIG. 18 is a perspective view of an illustrative antenna having a directly fed slot resonating element and an indirectly fed planar antenna resonating element with a serpentine path in accordance with an embodiment of the present invention.

FIG. 19 is a perspective view of an illustrative antenna having a directly fed slot resonating element and an indirectly fed multibranch planar antenna resonating element in accordance with an embodiment of the present invention.

FIG. 20 is a perspective view of an illustrative antenna having a directly fed slot antenna resonating element and an indirectly fed antenna resonating element in which the indirectly fed antenna resonating element is formed from a strip of conductor mounted on a support structure in accordance with an embodiment of the present invention.

FIG. 21 is a perspective view of an illustrative antenna having a directly fed slot antenna resonating element and an indirectly fed antenna resonating element in which an induc-

tor is placed across the terminals of the antenna in accordance with an embodiment of the present invention.

FIG. 22 is a perspective view of an illustrative antenna having a directly fed slot antenna resonating element and an indirectly fed antenna resonating element in which a capacitor is placed across the slot in accordance with an embodiment of the present invention.

FIG. 23 is a perspective view of an illustrative antenna having a directly fed slot antenna resonating element and an indirectly fed antenna resonating element in which an inductor is coupled to the indirectly fed antenna resonating element in accordance with an embodiment of the present invention.

FIG. 24 is a perspective view of an illustrative antenna having a directly fed slot antenna resonating element and an indirectly fed antenna resonating element in which a capacitor is coupled to the indirectly fed antenna resonating element in accordance with an embodiment of the present invention.

FIG. 25 is a top view of an illustrative slot antenna resonating element having two openings that may be used in an antenna in accordance with an embodiment of the present invention.

FIG. 26 is a top view of an illustrative multibranch slot antenna resonating element that may be used in an antenna in accordance with an embodiment of the present invention.

DETAILED DESCRIPTION

The present invention relates generally to wireless communications, and more particularly, to wireless electronic devices and antennas for wireless electronic devices.

The wireless electronic devices may be portable electronic devices such as laptop computers or small portable computers of the type that are sometimes referred to as ultraportables. Portable electronic devices may also be somewhat smaller devices. Examples of smaller portable electronic devices include wrist-watch devices, pendant devices, headphone and earpiece devices, and other wearable and miniature devices. With one suitable arrangement, which is sometimes described herein as an example, the portable electronic devices are handheld electronic devices.

The handheld devices may be, for example, cellular telephones, media players with wireless communications capabilities, handheld computers (also sometimes called personal digital assistants), remote controllers, global positioning system (GPS) devices, and handheld gaming devices. The handheld devices may also be hybrid devices that combine the functionality of multiple devices of these types. Examples of hybrid handheld devices include a cellular telephone that includes media player functionality, a gaming device that includes a wireless communications capability, a cellular telephone that includes game and email functions, and a handheld device that receives email, supports mobile telephone calls, has music player functionality and supports web browsing. These are merely illustrative examples.

An illustrative handheld electronic device in accordance with an embodiment of the present invention is shown in FIG. 1. Device 10 may be any suitable portable or handheld electronic device.

Device 10 may have housing 12 and may include one or more antennas for handling wireless communications. Device 10 may handle communications over multiple communications bands. For example, wireless communications circuitry in device 10 may be used to handle cellular telephone communications in one or more frequency bands and data communications in one or more communications bands. With one suitable arrangement, which is sometimes described herein as an example, the wireless communications

circuitry of device **10** may use a first antenna that is configured to handle communications in one or more communications bands and may use a second antenna that is configured to handle communications in one or more additional communications band. The first antenna may, for example, handle communications in a communications band that is centered at 2.4 GHz (e.g., Wi-Fi and/or Bluetooth frequencies) while simultaneously receiving Global Positioning Systems (GPS) communications at 1575 MHz. The second antenna may handle cellular telephone communications bands and/or 3G data communications bands such as the Universal Mobile Telecommunications System (UMTS) 3G data communications band at 2170 MHz (as examples).

Housing **12**, which is sometimes referred to as a case, may be formed of any suitable materials including plastic, glass, ceramics, metal, other suitable materials, or a combination of these materials. In some situations, housing **12** or portions of housing **12** may be formed from a dielectric or other low-conductivity material, so that the operation of conductive antenna elements that are located in proximity to housing **12** is not disrupted. Housing **12** or portions of housing **12** may also be formed from conductive materials such as metal.

An illustrative housing material that may be used is anodized aluminum. Aluminum is relatively light in weight and, when anodized, has an attractive insulating and scratch-resistant surface. If desired, other metals can be used for the housing of device **10**, such as stainless steel, magnesium, titanium, alloys of these metals and other metals, etc. In scenarios in which housing **12** is formed from metal elements, one or more of the metal elements may be used as part of the antenna in device **10**. For example, metal portions of housing **12** may be shorted to an internal ground plane in device **10** to create a larger ground plane element for that device **10**. To facilitate electrical contact between an anodized aluminum housing and other metal components in device **10**, portions of the anodized surface layer of the anodized aluminum housing may be selectively removed during the manufacturing process (e.g., by laser etching).

Housing **12** may have a bezel **14**. The bezel **14** may be formed from a conductive material. The conductive material may be a metal (e.g., an elemental metal or an alloy) or other suitable conductive materials. With one suitable arrangement, which is sometimes described herein as an example, bezel **14** may be formed from stainless steel. Stainless steel can be manufactured so that it has an attractive shiny appearance, is structurally strong, and does not corrode easily. If desired, other structures may be used to form bezel **14**. For example, bezel **14** may be formed from plastic that is coated with a shiny coating of metal or other suitable substances.

Bezel **14** may serve to hold a display or other device with a planar surface in place on device **10**. As shown in FIG. 1, for example, bezel **14** may be used to hold display **16** in place by attaching display **16** to housing **12**. Device **10** may have front and rear planar surfaces. In the example of FIG. 1, display **16** is shown as being formed as part of the planar front surface of device **10**. The periphery of the front surface may be surrounded by bezel **14**. If desired, the periphery of the rear surface may be surrounded by a bezel (e.g., in a device with both front and rear displays).

Display **16** may be a liquid crystal diode (LCD) display, an organic light emitting diode (OLED) display, or any other suitable display. The outermost surface of display **16** may be formed from one or more plastic or glass layers. If desired, touch screen functionality may be integrated into display **16** or may be provided using a separate touch pad device. An advantage of integrating a touch screen into display **16** to

make display **16** touch sensitive is that this type of arrangement can save space and reduce visual clutter.

In a typical arrangement, bezel **14** may have prongs that are used to secure bezel **14** to housing **12** and that are used to electrically connect bezel **14** to housing **12** and other conductive elements in device **10**. The housing and other conductive elements form a ground plane for the antenna(s) in the handheld electronic device. A gasket (e.g., an o-ring formed from silicone or other compliant material, a polyester film gasket, etc.) may be placed between the underside of bezel **14** and the outermost surface of display **16**. The gasket may help to relieve pressure from localized pressure points that might otherwise place stress on the glass or plastic cover of display **16**. The gasket may also help to visually hide portions of the interior of device **10** and may help to prevent debris from entering device **10**.

In addition to serving as a retaining structure for display **16**, bezel **14** may serve as a rigid frame for device **10**. In this capacity, bezel **14** may enhance the structural integrity of device **10**. For example, bezel **14** may make device **10** more rigid along its length than would be possible if no bezel were used. Bezel **14** may also be used to improve the appearance of device **10**. In configurations such as the one shown in FIG. 1 in which bezel **14** is formed around the periphery of a surface of device **10** (e.g., the periphery of the front face of device **10**), bezel **14** may help to prevent damage to display **16** (e.g., by shielding display **16** from impact in the event that device **10** is dropped, etc.).

Display screen **16** (e.g., a touch screen) is merely one example of an input-output device that may be used with handheld electronic device **10**. If desired, handheld electronic device **10** may have other input-output devices. For example, handheld electronic device **10** may have user input control devices such as button **19**, and input-output components such as port **20** and one or more input-output jacks (e.g., for audio and/or video). Button **19** may be, for example, a menu button. Port **20** may contain a 30-pin data connector (as an example). Openings **24** and **22** may, if desired, form microphone and speaker ports. Display screen **16** may be, for example, a liquid crystal display (LCD), an organic light-emitting diode (OLED) display, a plasma display, or multiple displays that use one or more different display technologies. In the example of FIG. 1, display screen **16** is shown as being mounted on the front face of handheld electronic device **10**, but display screen **16** may, if desired, be mounted on the rear face of handheld electronic device **10**, on a side of device **10**, on a flip-up portion of device **10** that is attached to a main body portion of device **10** by a hinge (for example), or using any other suitable mounting arrangement.

A user of handheld device **10** may supply input commands using user input interface devices such as button **19** and touch screen **16**. Suitable user input interface devices for handheld electronic device **10** include buttons (e.g., alphanumeric keys, power on-off, power-on, power-off, and other specialized buttons, etc.), a touch pad, pointing stick, or other cursor control device, a microphone for supplying voice commands, or any other suitable interface for controlling device **10**. Although shown as being formed on the top face of handheld electronic device **10** in the example of FIG. 1, buttons such as button **19** and other user input interface devices may generally be formed on any suitable portion of handheld electronic device **10**. For example, a button such as button **19** or other user interface control may be formed on the side of handheld electronic device **10**. Buttons and other user interface controls can also be located on the top face, rear face, or other portion of device **10**. If desired, device **10** can be controlled remotely

(e.g., using an infrared remote control, a radio-frequency remote control such as a Bluetooth remote control, etc.).

Handheld device **10** may have ports such as port **20**. Port **20**, which may sometimes be referred to as a dock connector, 30-pin data port connector, input-output port, or bus connector, may be used as an input-output port (e.g., when connecting device **10** to a mating dock connected to a computer or other electronic device). Device **10** may also have audio and video jacks that allow device **10** to interface with external components. Typical ports include power jacks to recharge a battery within device **10** or to operate device **10** from a direct current (DC) power supply, data ports to exchange data with external components such as a personal computer or peripheral, audio-visual jacks to drive headphones, a monitor, or other external audio-video equipment, a subscriber identity module (SIM) card port to authorize cellular telephone service, a memory card slot, etc. The functions of some or all of these devices and the internal circuitry of handheld electronic device **10** can be controlled using input interface devices such as touch screen display **16**.

Components such as display **16** and other user input interface devices may cover most of the available surface area on the front face of device **10** (as shown in the example of FIG. 1) or may occupy only a small portion of the front face of device **10**. Because electronic components such as display **16** often contain large amounts of metal (e.g., as radio-frequency shielding), the location of these components relative to the antenna elements in device **10** should generally be taken into consideration. Suitably chosen locations for the antenna elements and electronic components of the device will allow the antennas of handheld electronic device **10** to function properly without being disrupted by the electronic components.

Handheld electronic device **10** may have one or more antennas. For example, handheld electronic device may have a first antenna that is located in the upper end of device **10** in region **21** and a second antenna that is located in the lower end of device **10** in region **18**. Additional antennas or only a single antenna may be used in device **10** if desired.

In an illustrative arrangement with two antennas, the first antenna may be a multiband antenna that covers two or more frequency bands of interest such as the Wi-Fi/Bluetooth band at 2.4 GHz and the GPS band at 1575 MHz and the second antenna may be used to cover bands such as cellular telephone bands, data bands (e.g., 3G data bands), etc. An advantage of locating the first and second antennas at opposite ends of device **10** is that this separates the antennas from each other and helps to reduce the possibility of radio-frequency interference.

A schematic diagram of an embodiment of an illustrative handheld electronic device is shown in FIG. 2. Handheld device **10** may be a mobile telephone, a mobile telephone with media player capabilities, a handheld computer, a remote control, a game player, a global positioning system (GPS) device, a combination of such devices, or any other suitable portable electronic device.

As shown in FIG. 2, handheld device **10** may include storage **34**. Storage **34** may include one or more different types of storage such as hard disk drive storage, nonvolatile memory (e.g., flash memory or other electrically-programmable-read-only memory), volatile memory (e.g., battery-based static or dynamic random-access-memory), etc.

Processing circuitry **36** may be used to control the operation of device **10**. Processing circuitry **36** may be based on a processor such as a microprocessor and other suitable integrated circuits. With one suitable arrangement, processing circuitry **36** and storage **34** are used to run software on device **10**, such as internet browsing applications, voice-over-inter-

net-protocol (VOIP) telephone call applications, email applications, media playback applications, operating system functions, etc. Processing circuitry **36** and storage **34** may be used in implementing suitable communications protocols. Communications protocols that may be implemented using processing circuitry **36** and storage **34** include internet protocols, wireless local area network protocols (e.g., IEEE 802.11 protocols—sometimes referred to as Wi-Fi®), protocols for other short-range wireless communications links such as the Bluetooth® protocol, protocols for handling 3G data services such as UMTS, Global Positioning System (GPS) protocols, cellular telephone communications protocols, etc.

Input-output devices **38** may be used to allow data to be supplied to device **10** and to allow data to be provided from device **10** to external devices. Display screen **16**, button **19**, microphone port **24**, speaker port **22**, and dock connector port **20** are examples of input-output devices **38**.

Input-output devices **38** can include user input-output devices **40** such as buttons, touch screens, joysticks, click wheels, scrolling wheels, touch pads, key pads, keyboards, microphones, cameras, etc. A user can control the operation of device **10** by supplying commands through user input devices **40**. Display and audio devices **42** may include liquid-crystal display (LCD) screens or other screens, light-emitting diodes (LEDs), and other components that present visual information and status data. Display and audio devices **42** may also include audio equipment such as speakers and other devices for creating sound. Display and audio devices **42** may contain audio-video interface equipment such as jacks and other connectors for external headphones and monitors.

Wireless communications devices **44** may include communications circuitry such as radio-frequency (RF) transceiver circuitry formed from one or more integrated circuits, power amplifier circuitry, passive RF components, one or more antennas, and other circuitry for handling RF wireless signals. Wireless signals can also be sent using light (e.g., using infrared communications).

Device **10** can communicate with external devices such as accessories **46** and computing equipment **48**, as shown by paths **50**. Paths **50** may include wired and wireless paths. Accessories **46** may include headphones (e.g., a wireless cellular headset or audio headphones) and audio-video equipment (e.g., wireless speakers, a game controller, or other equipment that receives and plays audio and video content).

Computing equipment **48** may be any suitable computer. With one suitable arrangement, computing equipment **48** is a computer that has an associated wireless access point (router) or an internal or external wireless card that establishes a wireless connection with device **10**. The computer may be a server (e.g., an internet server), a local area network computer with or without internet access, a user's own personal computer, a peer device (e.g., another handheld electronic device **10**), or any other suitable computing equipment.

The antenna structures and wireless communications devices of device **10** may support communications over any suitable wireless communications bands. For example, wireless communications devices **44** may be used to cover communications frequency bands such as the cellular telephone bands at 850 MHz, 900 MHz, 1800 MHz, and 1900 MHz, data service bands such as the 3G data communications band at 2170 MHz (commonly referred to as the UMTS or Universal Mobile Telecommunications System band), the Wi-Fi® (IEEE 802.11) bands at 2.4 GHz and 5.0 GHz (also sometimes referred to as wireless local area network or WLAN bands), the Bluetooth® band at 2.4 GHz, and the global positioning system (GPS) band at 1575 MHz. The 850 MHz band is sometimes referred to as the Global System for

Mobile (GSM) communications band. The 900 MHz communications band is sometimes referred to as the Extended GSM (EGSM) band. The 1800 MHz band is sometimes referred to as the Digital Cellular System (DCS) band. The 1900 MHz band is sometimes referred to as the Personal Communications Service (PCS) band.

Device **10** can cover these communications bands and/or other suitable communications bands with proper configuration of the antenna structures in wireless communications circuitry **44**.

A cross-sectional view of an illustrative handheld electronic device is shown in FIG. **3**. In the example of FIG. **3**, device **10** has a housing that is formed of a conductive portion **12-1** and dielectric portions **12-2A** and **12-2B** (e.g., portions **12-2A** and **12-2B** that are formed from plastic). Conductive portion **12-1** may be any suitable conductor such as aluminum, magnesium, stainless steel, alloys of these metals and other metals, etc. Conductive portion **12-1** may include a substantially rectangular conductive rear housing surface and housing side walls. Dielectric portions **12-2A** and **12-2B** may serve as caps that cover antennas that are mounted within housing **12**. With one suitable arrangement, dielectric portions **12-2A** and **12-2B** may lie flush with the exterior surfaces of housing **12** (i.e., with the rear surface and sidewall surfaces of conductive housing portion **12-1**).

There are two antennas in the example of FIG. **3**. A first of the two antennas is formed from antenna resonating element **54-1B** and antenna ground plane **54-2**. A second of the two antennas is formed from antenna resonating element **54-1A** and ground plane **54-2**. In addition to antenna resonating element **54-1B**, the first antenna may have a slot antenna resonating element. The slot antenna resonating element may be provided in the form of one or more openings in antenna ground plane **54-2** in the vicinity of antenna resonating element **54-1A**. Because antenna resonating elements such as elements **54-1A** and **54-1B** and the slot antenna resonating element are used to support far-field communications (e.g., to transmit radio-frequency signals to external equipment and to receive radio-frequency signals from external equipment), antenna resonating elements such as these are sometimes referred to as antenna radiating elements.

Resonating element **54-1B** in antenna **54** may be formed from an elongated resonating element structure such as an L-shaped strip or arm (branch). Multibranch structures and structures with planar portions may be used for resonating element **54-1B** if desired. Resonating element **54-1B** may be formed from any suitable conductive structure such as a length of wire, a strip of metal foil or other conductor, or traces on a flex circuit, etc.

An advantage of using dielectric for housing portions **12-2A** and **12-2B** is that this allows the antennas of device **10** to operate without interference from the metal sidewalls of housing **12**. With one suitable arrangement, housing portions **12-2A** and **12-2B** may be plastic caps formed from a plastic based on acrylonitrile-butadiene-styrene copolymers (sometimes referred to as ABS plastic). These are merely illustrative housing materials for device **10**. For example, the housing of device **10** may be formed substantially from plastic or other dielectrics, substantially from metal or other conductors, or from any other suitable materials or combinations of materials.

Components such as components **52** may be mounted on circuit boards in device **10**. The circuit board structures in device **10** may be formed from any suitable materials. Suitable circuit board materials include paper impregnated with phenolic resin, resins reinforced with glass fibers such as fiberglass mat impregnated with epoxy resin (sometimes

referred to as FR-4), plastics, polytetrafluoroethylene, polystyrene, polyimide, and ceramics. Circuit boards fabricated from materials such as FR-4 are commonly available, are not cost-prohibitive, and can be fabricated with multiple layers of metal (e.g., four layers). So-called flex circuits, which are flexible circuit board materials such as polyimide, may also be used in device **10**.

Typical components in device **10** include integrated circuits, LCD screens, and user input interface buttons. Device **10** also typically includes a battery, which may be mounted along the rear face of housing **12** (as an example).

Because of the conductive nature of components such as these and the printed circuit boards upon which these components are mounted, the components, circuit boards, and conductive housing portions (including bezel **14**) of device **10** may be grounded together to form antenna ground plane **54-2**. With one illustrative arrangement, ground plane **54-2** may conform to the generally rectangular shape of housing **12** and device **10** and may match the rectangular lateral dimensions of housing **12**.

Any suitable conductive materials may be used to form ground plane element **54-2** and resonating elements **54-1A** and **54-1B**. Examples of suitable conductive materials for the antenna structures in device **10** include elemental metals, such as copper, silver, and gold, and metal alloys (e.g., beryllium copper). Conductors other than metals may also be used, if desired.

Components **52** may include transceiver circuitry (see, e.g., devices **44** of FIG. **2**). The transceiver circuitry may be provided in the form of one or more integrated circuits and associated discrete components (e.g., filtering components). The transceiver circuitry may include one or more transmitter integrated circuits, one or more receiver integrated circuits, switching circuitry, amplifiers, etc. Each transceiver in the transceiver circuitry may have an associated coaxial cable, microstrip transmission line, or other transmission line that is connected to an associated antenna and over which radio frequency signals are conveyed. In the example of FIG. **3**, transmission lines are depicted by dashed line **56**.

Transmission lines **56** may be used to distribute radio-frequency signals that are to be transmitted through the antennas from a transmitter integrated circuit **52**. Paths **56** may also be used to convey radio-frequency signals that have been received by an antenna to components **52**. Components **52** may include one or more receiver integrated circuits for processing incoming radio-frequency signals.

As shown in the cross-sectional diagram of FIG. **3**, it may be advantageous to locate the antennas in device **10** near the extremities of device **10** (e.g., at either end of device **10**). If desired, the antenna formed from antenna resonating element **54-1A** and ground plane **54-2** may be omitted. If this antenna is omitted from device **10**, there may be additional space available for components **52** in housing **12** or the size of housing **12** may be reduced.

Part of the frequency response of antenna **54** may be obtained by forming an opening within ground plane **54-2** that resonates in a desired frequency band (e.g., the lower frequency band in a two-band arrangement). The opening, which is sometimes referred to as a slot, may have any suitable shape. For example, the slot may be rectangular, the slot may have curved sides, the slot may have any suitable number of straight sides, the slot may have a combination of straight sides and curved sides, etc.

In operation, the portion of antenna **54** that contains the slot forms a slot antenna. The slot antenna structure in antenna **54** can be used at the same time as a non-slot antenna resonating element (e.g., an L-shaped strip). In particular, antenna per-

formance can be improved when operating antenna **54** as a hybrid device in which both its non-slot antenna resonating element operating characteristics and its slot antenna resonating element operating characteristics are present. In hybrid operation, the slot antenna portion of the antenna may provide a frequency response in a lower frequency communications band, whereas the L-shaped arm (or other non-slot portion) portion of the antenna may provide a frequency response in a higher frequency communications band (as an example).

A top view of an illustrative slot antenna is shown in FIG. **4**. Antenna **72** of FIG. **4** is typically thin in the dimension into the page (i.e., antenna **72** is planar with its plane lying in the page). Slot **70** may be formed in the center of antenna **72**. Slot **70** of FIG. **4** is shown as being rectangular in shape as an example, but in general, slot **70** may have any suitable shape.

Coaxial cable **56** or any other suitable transmission line may be used to feed antenna **72**. In the example of FIG. **4**, antenna **72** is fed so that positive or center conductor **82** of coaxial cable **56** is connected to signal terminal **80** (i.e., the positive terminal of antenna **72**) and the outer braid of coaxial cable **56**, which forms the ground conductor for cable **56**, is connected to ground terminal **78**. Antenna terminals such as terminals **80** and **78** are sometimes referred to as feed terminals or are said to form an antenna feed. Because signals from transmission line **56** are applied to the slot resonating element of antenna **72** directly through the antenna's positive and ground terminals, arrangements such as the one shown in FIG. **4** are sometimes referred to as direct feed arrangements.

When the slot antenna resonating element of antenna **72** is directly fed using an arrangement of the type shown in FIG. **4**, the antenna's performance is given by the graph of FIG. **5**. As shown in FIG. **5**, antenna **72** operates in a frequency band that is centered about center or resonant frequency f_r . The center frequency f_r is determined by the dimensions of slot **70**. Slot **70** of FIG. **4** has an inner perimeter P that is equal to two times dimension X plus two times dimension Y (i.e., $P=2X+2Y$). At center frequency f_r , perimeter P is equal to one wavelength. The position of terminals **80** and **78** may be selected for impedance matching. If desired, terminals such as terminals **84** and **86**, which extend around one of the corners of slot **70** may be used to directly feed antenna **72**, provided that the distance between terminals **84** and **86** is chosen to properly adjust the impedance of antenna **72**. Optional impedance matching network components may also be used for impedance matching.

In the illustrative arrangement of FIG. **4**, terminals **84** and **86** are shown as being respectively configured as a slot antenna ground terminal and a slot antenna signal terminal, as an example. If desired, terminal **84** could be used as a ground terminal and terminal **86** could be used as a signal terminal. Slot **70** is typically an air-filled slot, but may, in general, be filled with any suitable dielectric. If desired, space may be conserved in handheld electronic device **10** by allowing components in device **10** to be placed in the vicinity of slot **70**. For example, dielectric parts or small conductive parts may impinge somewhat on slot **70** without preventing antenna **72** from functioning properly.

An arrangement in which slot **70** has a non-rectangular shape is shown in FIG. **6**.

The shape of slot **70** may be defined by the shape of an opening in planar ground plane elements such as a printed circuit board or other mounting structure. The shape of slot **70** may also be defined by the layout of conductive components within device **10**. For example, on end of a rectangular slot may be defined by the presence of a component with metal parts.

With one suitable arrangement, the shape of slot **70** is defined by an opening that is formed by bezel **14** and the printed circuit board structures, planar housing surfaces, and conductive components **52** in device **10** that form ground plane **54-2**. An illustrative arrangement of this type is shown in FIG. **7**. In the example of FIG. **7**, slot **70** has a shape that is determined by the size and shape of the opening formed between conductive bezel **14** (which may be considered to be part of ground plane **54-2**) and the other portions of ground plane **54-2**. Slots whose shapes are determined in this way may have any suitable shape (e.g., rectangular, irregular shapes with curved and straight sides, etc.). An advantage of using bezel **14** to form part of the sides of slot **70** and thereby determine the shape of slot **70** is that this allows a conductive bezel to be formed around the entire periphery of device **10** while locating antenna **54** near to one of the ends of device **10**.

Any suitable feed arrangement may be used to feed antenna **54**. With one suitable arrangement, which is described herein as an example, the slot antenna resonating element of antenna **54** is directly fed (e.g., using antenna feed terminals such as positive antenna terminal **80** or **84** of FIG. **4** and ground antenna terminals such as ground antenna terminal **78** or **86** in FIG. **4**).

In a direct feeding arrangement for the slot of antenna **54**, a ground conductor in a coaxial cable or other transmission line **56** may be coupled to an antenna ground terminal on one portion of the slot's periphery while a center or positive conductor in a coaxial cable or other transmission line **56** may be coupled to a positive antenna terminal on another portion of the slot's periphery. The ground and positive antenna terminals may, for example, be located on opposite sides of a slot that has a rectangular portion as shown in FIG. **4**. In addition to the directly fed slot resonating element, antenna **54** also may have an additional resonating element. The additional resonating element may be formed using a non-slot structure that is indirectly fed. For example, this other antenna resonating element may be formed from an indirectly fed length of conductor or an indirectly fed planar structure.

With an indirect feed arrangement, the non-slot resonating element is coupled to the slot resonating element by near-field electromagnetic coupling, rather than being directly fed through the positive and ground antenna terminals. Due to this near-field electromagnetic interaction, transmitted signals from the transmission line can be coupled onto the non-slot resonating element by way of the directly fed slot resonating element. Similarly, signals can be received using the non-slot resonating element because the non-slot resonating element is near-field coupled to the slot antenna resonating element that is directly coupled to the transmission line.

By proper selection of the resonant frequencies for the directly fed slot antenna resonating element and the indirectly fed antenna resonating element, a desired amount of frequency coverage for antenna **54** may be obtained.

An illustrative antenna having a slot antenna resonating element that is directly fed and a non-slot antenna resonating element that is indirectly fed is shown in FIG. **8**. As shown in FIG. **8**, antenna **54** may be fed by transmission line **56**. Antenna **54** may have slot antenna resonating element **70** and L-shaped antenna resonating element **54-1B**. Slot resonating element **70** may be formed from an opening in antenna ground plane **54-2**. L-shaped antenna resonating element **54-1B** may have one end (e.g., end **88**) that is connected to ground plane **54-2** and another end (e.g., end **90**) that is positioned away from ground plane **54-2**. Ground plane **54-2** may serve as a ground plane for both the slot antenna portion of antenna **54** and the non-slot antenna portion of antenna **54**.

13

Because antenna **54** has both slot and non-slot portions, antenna **54** may sometimes be referred to as a hybrid antenna.

In antenna **54** of FIG. **8**, slot antenna resonating element **70** is shown as being directly fed, whereas non-slot antenna element **70** is shown as being indirectly fed. Slot **70** may be directly fed using any suitable arrangement. As shown in FIG. **8**, for example, slot **70** may be directly fed by transmission line **56** at ground antenna terminal **78** and positive antenna terminal **80**. A ground conductor associated with transmission line **56** may be connected to terminal **78**. Center conductor **82** of transmission line **56** may be connected to positive terminal **80**. Transmission line **56** may be a coaxial cable or any other suitable transmission line.

Slot resonating element **70** may have an antenna resonance at a frequency that is determined by its inner perimeter P , as described in connection with FIGS. **4** and **5**. Resonating element **54-1B** may have an antenna resonance at a frequency that is determined by its shape. For example, if resonating element **54-1B** has a length L , resonating element **54-1B** may resonate at a frequency at which L is equal to a quarter of a wavelength. These resonant frequencies need not be equal to each other and may or may not have other relationships with each other. For example, the slot resonant frequency may or may not be equal to a harmonic of the non-slot resonant frequency. The perimeter of slot **70** may be adjusted independently from the length (or other characteristic) associated with resonating element **54-1B**, which allows an antenna designer to independently position the resonant peaks of slot **70** and antenna resonating element **54-1B**.

As shown in FIG. **9**, for example, slot **70** and resonating element **54-1B** may be configured so that antenna **54** covers two distinct communications bands—a first band that is centered at frequency f_1 and a second centered at frequency f_2 . Slot **70** may be used to cover either the first or the second communications band, while element **54-1B** may be used to cover the remaining band.

As shown in FIG. **10**, slot **70** and resonating element **54-1B** may be configured so that antenna **54** covers a single communications band. With the illustrative arrangement shown in FIG. **10**, the resonant frequencies of the slot and the non-slot resonating element have been configured to be close to each other. As a result, the frequency responses of these portions of antenna **54** have merged to cover a single band.

If the resonant frequencies are configured to be the same (i.e., if slot **70** and element **54-1B** are configured so that f_1 equals f_2), the resonant peak associated with slot **70** will coincide with the resonant peak associated with element **54-1B**. This may improve antenna performance at or near the resonant frequency. For example, antenna **54** may exhibit improved immunity to the position of a user's hand on device **10** when compared to an antenna that does not contain both slot **70** and element **54-1B**. Providing immunity to proximity effects in this way may make the wireless performance of device **10** more robust.

If the resonant frequencies are configured to be slightly different, one resonating element will cover a lower portion of the communications band, whereas the other resonating element will cover an upper portion of the communications band. This type of arrangement, which is depicted in FIG. **10** allows the bandwidth of the antenna within a desired communications band to be broadened and may improve immunity to proximity effects.

Another suitable arrangement is shown in FIG. **11**. In the example of FIG. **11**, slot **70** and element **54-1B** are configured to cover more than two frequency bands. In particular, antenna **54** of FIG. **11** covers bands centered at frequencies f_1 , f_2 , and f_3 . Slot **70** and element **54-1B** may, for example, be

14

configured to cover two of these bands. The third band may be covered by a harmonic of either slot **70** or element **54-1B**. If desired, more than three bands may be covered by using additional harmonics.

It is not necessary for resonating element **54-1B** to be placed on one side of slot **70** as shown in the illustrative arrangement of FIG. **8**. For example, resonating element **54-1B** may be located so that most or all of element **54-1B** overlaps slot **70**, as shown in FIG. **12**.

Another suitable arrangement is shown in FIG. **13**. As shown by the illustrative antenna configuration of FIG. **13**, antenna **54** may have a resonating element such as resonating element **54-1B** that is not L-shaped. Illustrative resonating element **54-1B** of FIG. **13** has three portions. A first portion (portion **92**) extends vertically away from ground plane **54-2** (which may be formed by planar structures such as housing surfaces, electrical components, and circuit boards). A second portion (portion **94**) extends parallel to ground plane **54-2** and runs across slot **70** perpendicular to longitudinal axis **98** of slot **70**. A third portion (portion **96**) extends parallel to ground plane **54-2** and runs parallel to longitudinal axis **98**.

With the illustrative configuration of FIG. **14**, antenna resonating element **54-1B** has vertically extending portion **100** and horizontally extending portion **102**. Portion **100** may be perpendicular to ground plane **54-2**. Portion **102** may extend parallel to ground plane **54-2** across slot **70** and may be configured to be perpendicular to longitudinal axis **98** of slot **70**.

FIG. **15** shows an illustrative configuration for antenna resonating element **54-1B** in which element **54-1B** has multiple portions crossing slot **70**. Vertical member **104** may extend upwards from ground plane **54-2**. Antenna resonating element portion **106** may extend across slot **70** perpendicular to slot longitudinal axis **98**. Portion **108** of antenna resonating element **54-1B** may extend parallel to ground plane **54-2** and longitudinal axis **98**. Portion **110** may cross slot **70** and may be perpendicular to longitudinal axis **98**.

As shown in FIG. **16**, antenna resonating element **54-1B** may have multiple branches. In the illustrative configuration of FIG. **16**, antenna resonating element **54-1B** has branch **112** and branch **114**. Conductor **116** may be used to connect branch **114** to vertical resonating element portion **118**. Although resonating element **54-1B** of FIG. **16** has two branches, antenna **54** may, in general, be formed using an antenna resonating element with any suitable number of branches (e.g., three or more branches). The branches of antenna resonating element **54-1B** may have different lengths. For example, one branch (such as branch **112** of FIG. **16**) may have a relatively longer length, so that it resonates at a relatively lower frequency, whereas another branch (such as branch **114** of FIG. **16**) may have a relatively shorter length, so that it resonates at a relatively higher frequency. The frequency peaks associated with the different branches may be used to cover different communications bands of interest, to increase the antenna bandwidth associated with a given communications band or bands, etc.

The illustrative antenna arrangements of FIG. **8** and FIGS. **12-16** are merely illustrative. Antenna resonating elements such as these may be provided with additional bends, fewer bends, curved lengths of conductor, different numbers of branches, or other shapes or structures if desired. The lengths of conductor in these antenna resonating elements may be formed from wires, conductive traces (e.g., traces on a flex circuit substrate), portions of metal foil, or other suitable conductive structures.

If desired, antenna **54** may be formed from a directly fed slot and an indirectly fed planar antenna resonating element.

15

An illustrative antenna configuration of this type is shown in FIG. 17. As shown in FIG. 17, slot resonating element 70 may be directly fed by transmission line 56 using ground and positive antenna terminals located (for example) on opposite sides of slot 70. In the arrangement of FIG. 17, antenna resonating element 54-1B has at least one conductive structure that is planar (i.e., planer upper portion 122). Antenna resonating element 54-1B also preferably has at least one conductive structure that connects the planar structure to ground plane 54-2.

Planar portion 122 may be parallel to ground plane 54-2. A vertical conductive structure such as planar conductive structure 120 may be used to connect planar structure 122 to ground plane 54-2. If desired, other conductive structures may be used to connect planar antenna structures in resonating element 54-1B to ground plane 54-2. For example, wires, strips of conductor, multiple vertical planar elements, or other suitable conductors may be used to connect planar antenna portion 122 to ground.

The electrical properties of planar structures such as planar antenna resonating element 54-1B may differ from those of substantially non-planar structures (e.g., those based on L-shaped wires or narrow traces on a flex circuit). For example, planar structures of the type shown in antenna resonating element 54-1B of FIG. 17 may exhibit a broader frequency response than non-planar antenna resonating elements.

If desired, other planar shapes may be used for antenna resonating element 54-1B. For example, planar portion 122 of antenna resonating element 54-1B may be implemented using a planar conductor that is configured to form a serpentine path as shown in FIG. 18. In the FIG. 18 example, resonating element 54-1B has planar upper portion 122 and vertical portion 120. Planar upper portion 122 has a serpentine path formed of path portion 128, path portion 126, and path portion 124. The length of the serpentine path (approximately equal to three times the length of an individual one of the path segments) may help establish the resonant frequency of antenna resonating element 54-1B. For example, if resonating element 54-1B has a portion 122 with a total length L for its serpentine path, resonating element 54-1B may resonate at a frequency at which L is equal to a quarter of a wavelength.

If desired, planar antenna resonating elements may be provided with multiple branches (arms). An illustrative arrangement in which planar portion 122 of antenna resonating element 54-1B has two branches is shown in FIG. 19. In this example, branch 130 is shorter than branch 132. To conserve space in device 10, branches such as branches 130 and 132 may fold back upon themselves one or more times as shown by the paths 124, 126, and 128 in the serpentine path example of FIG. 18. There may be any suitable number of branches in antenna resonating element 54-1B (e.g. two branches, more than two branches, etc.). The use of multiple branches in a planar antenna resonating element such as antenna resonating element 54-1B of FIG. 19 may help broaden antenna coverage in a particular band or bands or may help the antenna cover additional communications bands.

As shown in FIG. 20, the conductive structures of antenna resonating element 54-1B may be supported using support structures such as support structure 133. In the example of FIG. 20, a conductive strip of metal or other suitable conductor has been formed on a dielectric support structure (structure 133). The conductive portion of antenna resonating element 54-1B may, for example, be formed from a strip of metal foil or a conductive trace on a flex circuit substrate (as examples). Any suitable antenna structures may be mounted

16

using support structures such as support structure 133. For example, planar antennas and non-planar antennas may be supported in this way. Elements with multiple branches, bends, serpentine paths, etc. may also be supported using one or more antenna resonating element support structures. The configuration of FIG. 20 is merely illustrative.

If desired, electrical components may be used to adjust the feed characteristics of antenna 52. For example, an inductor such as inductor 135 may be connected between the ground and positive antenna terminals 78 and 80 (e.g., for impedance matching to transmission line 56), as shown in FIG. 21.

As shown in FIG. 22, a capacitor such as capacitor 134 can be used to bridge slot 70. When capacitor 134 is electrically connected between terminals such as terminals 136 and 138 at different positions across slot 70, slot 70 behaves as if it has a larger perimeter P (i.e., by resonating at a lower frequency) at the expense of somewhat reduced efficiency and bandwidth. Arrangements such as the illustrative capacitor arrangement of FIG. 22 may be considered to be examples of antenna slot tuning networks.

If desired, antenna 54 can be tuned by connecting electrical components to antenna resonating element 54-1B. For example, an inductor such as inductor 140 may be placed in vertical path portion 142 (or other suitable location) within antenna resonating element 54-1B as shown in FIG. 23. This type of configuration tends to make antenna resonating element 54-1B behave as if it were shorter than its actual length. In the example of FIG. 23, antenna resonating element 54-1B runs parallel to longitudinal axis 98 of slot 70.

As shown in FIG. 24, a capacitor such as capacitor 144 may be connected to antenna resonating element 54-1B. In the illustrative configuration of FIG. 24, antenna resonating element 54-1B is shown as having a vertical portion 148 that extends upwards from ground plane 54-2. Horizontal portion 150 of antenna resonating element 54-1B may run parallel to longitudinal axis 98 of slot 70. Vertical antenna resonating element portion 146 may connect horizontal portion 150 to ground plane 54-2. Capacitors such as capacitor 144 may be placed in the conductive path formed by portion 146. The presence of capacitor 144 in antenna 54 in the position shown in FIG. 24 makes antenna resonating element 54-1B behave as if it were physically longer than it is at the expense of antenna efficiency and bandwidth. For applications in which space is at a premium, it may be advantageous to place a capacitor in antenna 54 such as capacitor 144, as this may allow antenna resonating element 54-1B to meet space constraints while resonating at a desired resonant frequency for antenna 54.

If desired, slot antenna resonating element 70 may be provided with multiple portions each of which has a different associated resonant frequency. As shown in FIG. 25, for example, antenna 54 may have a slot resonating element such as slot resonating element 70 that is formed from two openings in ground plane 54-2. In particular, slot resonating element 70 may be formed from a first opening in ground plane 54-2 such as slot resonating element 70A and a second opening in ground plane 54-2 such as slot resonating element 70B. Slots such as slots 70A and 70B may have different inner perimeters and may therefore have different associated resonant frequency peaks. In the illustrative arrangement of FIG. 25, slot 70A has a smaller inner perimeter than slot 70B, so it is expected that slot 70A will resonate at a higher frequency than slot 70B. If slots 70A and 70B are close in size, the resonant frequency contributions from each slot may merge and contribute to broader bandwidth coverage in a single communications band. If slots 70A and 70B are of substantially different sizes, each may help to establish a separate

antenna resonant frequency that corresponds to a separate communications band. The size of slots such as slots 70A and 70B may be selected so that their associated antenna resonances coincide with or supplement the frequency coverage provided by near-field coupled antenna resonating element 54-1B. Although slot resonating element 70 of FIG. 25 is formed from two openings in ground plane 54-2, there may, in general, be any suitable number of ground plane openings in a given slot resonating element (e.g., three or more).

Another example is shown in FIG. 26. In this illustrative configuration, antenna 54 is formed from a slot that has multiple possible inner perimeters. In particular, slot resonating element 70 of FIG. 26 has portion 156, portion 158, and portion 160. Transmission line 56 may be used to directly feed branch 158 of slot 70. In this type of configuration, portions 156 and 158 may define a first slot portion having a first associated perimeter, as indicated by dashed line 152, whereas portions 158 and 160 may form a second slot portion having a second associated perimeter, as indicated by dotted line 154. Different feeding arrangements and different slot geometries may be used if desired. Such configurations may be used to produce slot perimeters that are close in length (e.g., when it is desired to broaden frequency coverage in a particular communications band), slot perimeters that are substantially different in length (e.g., when it is desired to provide antenna 54 with coverage in one or more additional communications bands, etc.). Additional perimeters may be provided by configuring slot 70 to have multiple separate openings (as with FIG. 25), multiple branches (as with FIG. 26), combinations of multiple openings and multiple branches, more than two or three openings or branches, or any other suitable configuration. Any of the antenna feeding arrangements, antenna resonating tuning arrangements, and geometries for antenna resonating element 54-1B may be used with any of the illustrative slot configurations if desired.

The foregoing is merely illustrative of the principles of this invention and various modifications can be made by those skilled in the art without departing from the scope and spirit of the invention.

What is claimed is:

1. A handheld electronic device antenna that is coupled to a transmission line, comprising:

a ground plane antenna element;

a slot antenna resonating element formed from an opening in the ground plane antenna element;

antenna terminals adjacent to the slot antenna resonating element with which the transmission line directly feeds the slot antenna resonating element; and

a near-field-coupled antenna resonating element that is indirectly fed by the transmission line through near field coupling with the directly fed slot antenna resonating element, wherein the near-field-coupled antenna resonating element has multiple branches each of which is associated with a separate antenna resonant frequency.

2. The handheld electronic device antenna defined in claim 1 wherein the near-field-coupled antenna resonating element comprises an L-shaped length of conductor.

3. The handheld electronic device antenna defined in claim 1 wherein the near-field-coupled antenna resonating element comprises a length of conductor.

4. The handheld electronic device antenna defined in claim 1, wherein the ground plane element comprises at least one planar conductive structure, wherein the near-field-coupled antenna resonating element comprises a planar conductive resonating element structure that lies parallel to the planar conductive structure of the ground plane element.

5. The handheld electronic device antenna defined in claim 1 wherein the near-field-coupled antenna resonating element comprises a planar conductive structure.

6. The handheld electronic device antenna defined in claim 1 wherein the slot antenna resonating element has a longitudinal axis and wherein the near-field-coupled antenna resonating element comprises a length of conductor that runs parallel to the longitudinal axis.

7. The handheld electronic device antenna defined in claim 1 wherein the slot antenna resonating element has a longitudinal axis and wherein the near-field-coupled antenna resonating element comprises a length of conductor that runs perpendicular to the longitudinal axis and parallel to the ground plane element.

8. A handheld electronic device antenna that is coupled to a transmission line, comprising:

a ground plane antenna element;

a slot antenna resonating element formed from an opening in the ground plane antenna element;

antenna terminals adjacent to the slot antenna resonating element with which the transmission line directly feeds the slot antenna resonating element;

a near-field-coupled antenna resonating element that is indirectly fed by the transmission line through near field coupling with the directly fed slot antenna resonating element; and

a capacitor, wherein the near-field-coupled antenna resonating element has an end at which the near-field-coupled antenna resonating element is connected to the ground plane element by the capacitor.

9. A handheld electronic device antenna that is coupled to a transmission line, comprising:

a ground plane antenna element;

a slot antenna resonating element formed from an opening in the ground plane antenna element;

antenna terminals adjacent to the slot antenna resonating element with which the transmission line directly feeds the slot antenna resonating element;

a near-field-coupled antenna resonating element that is indirectly fed by the transmission line through near field coupling with the directly fed slot antenna resonating element; and

an inductor, wherein the near-field-coupled antenna resonating element has an end at which the near-field-coupled antenna resonating element is connected to the ground plane element by the inductor.

10. A handheld electronic device antenna that is coupled to a transmission line, comprising:

a ground plane antenna element;

a slot antenna resonating element formed from an opening in the ground plane antenna element;

antenna terminals adjacent to the slot antenna resonating element with which the transmission line directly feeds the slot antenna resonating element;

a near-field-coupled antenna resonating element that is indirectly fed by the transmission line through near field coupling with the directly fed slot antenna resonating element; and

an inductor connected between the antenna terminals.

11. A handheld electronic device antenna that is coupled to a transmission line, comprising:

a ground plane antenna element;

a slot antenna resonating element formed from an opening in the ground plane antenna element;

antenna terminals adjacent to the slot antenna resonating element with which the transmission line directly feeds the slot antenna resonating element;

19

a near-field-coupled antenna resonating element that is indirectly fed by the transmission line through near field coupling with the directly fed slot antenna resonating element; and
a capacitor that is connected across the slot antenna resonating element.

12. The handheld electronic device antenna element defined in claim **1** wherein the near-field-coupled antenna resonating element comprises a serpentine conductive path located above the slot antenna resonating element.

20

13. The handheld electronic device antenna defined in claim **1** wherein the slot antenna resonating element has portions defining multiple associated inner perimeters.

14. The handheld electronic device antenna defined in claim **1** wherein the slot antenna resonating element is formed from multiple distinct openings in the ground plane element.

* * * * *